

- **Absolute Monotour/Multitour shaft encoder**
- **Many Variants available**
 - **Sturdy design for rough applications**
 - **Miniature version**
 - **Bearingless “Kit Encoder“ version with external magnet**
- **Measuring range**
 - **TBN: max. 65,536 steps/360°**
 - **TMN: max. 65,536 steps/rev. x 32.768 revolutions**
 - **TRN: max. 65,536 steps/rev. x 4096 revolutions**
- **Protection grade IP65/IP66 (IP68/ IP69K optional)**
- **Interfaces**
 - **CANopen Safety SIL2**
 - **CANopen (CiA DS 406 Encoder Profile, 4.1.0)**
- **ATEX Variants for use in zone 1/21 and 2/22**

KEY INFORMATION OVERVIEW

DESIGN & FUNCTION

- Sturdy housing made from seawater-resistant aluminium, austenitic steel (V2A or V4A) or ferritic standad and chrome steel (for high requirements of interference resistance against magnetic fields)
- Constructions with Ø 42, Ø 55, Ø 58, Ø 78 as well as special constructions (application-dependent)
- Redundant magnetic sensor systems for position detection
- Recording of rotations via an absolute Multitour transmission in the TRN model
- Recording of the revolutions by means of an electronic counter on the TMN model.
- Electrical connections via connector M12x1 (Bus In and Bus Out option) or via cable
- Optional housing potting to meet IP68/ IP69K requirements
- Interface as CANopen Safety SIL2 in accordance with IEC 61508

A positive-locking mechanical connection between the customer's shaft and the sensor shaft ensures that the magnet in the sensor shaft precisely reflects the rotation of the customer's shaft.

Safe operation is also possible in the bearingless version thanks to existing diagnostic functions.

FEATURES INTERFACE

With the TBN model, one rotation (max. 65,536 steps) is recorded.

With the subsequent absolute transmission, the TRN shaft encoder reaches a measuring range of up to 4096 rotations. With the CANopen Safety protocol, both the position value and the speed value (SRDO - Safety Relevant Data Object) meet the requirements of SIL2.

With an electronic counter, the TMN encoder achieves a measuring range of 32,768 revolutions while beeing supplied with power.

The values for the redundant system are compared and checked for plausibility. If the check is positive, the output will be normal and bit-inverted.

Comprehensive checks using CRC, timing monitoring, voltage monitoring etc. ensure that reliable position and speed values are output. The speed value can be parameterised via the gate time (1 to 1000 ms) depending on the specific application.

In the event of a fault, emergency protocols are issued and a fault listing is created. The target function here is to move to a safe state in the event of a fault. This is also referred to as the functional safety of the encoder.

Additionally position and speed values (PDO - Process Data Object) can be output via the CANopen standard protocol.

TECHNICAL DATA

ELECTRICAL DATA

Sensor system	Magnetic sensor system
Operating voltage	9 to 36 VDC with reverse-polarity protection and short-circuit protection
Power consumption	TBN/TMN: < 1 W TRN: < 1.5 W
Resolution / Total step count	TBN: max. 65,536 steps, 16 Bit (steps/360°) TMN: max. 2,147,483,648 steps, 16 Bit singleturn (65,536 steps/revolution) x 15 Bit multiturn (32,768 revolutions) TRN: max. 268,435,456 steps, 16 Bit singleturn (65,536 steps/revolution) x 12 Bit multiturn (4096 revolutions)
Speed value	In addition to the position signal, a digits/gate time speed signal is also generated, which can be configured by the customer via an adjustable gate time, multiplier and divider for the application. <ul style="list-style-type: none"> ■ Speed value data format 16 Bit (signed) ■ Gate time 1 to 1000 ms ■ Internal sampling frequency 1ms ■ Maximum speed 15,000 rpm (mechanical limit, see: mechanical data)
Code sense	CW* or CCW**, parameterisable
Reference value	0 to (total step count -1)
Accuracy TBN/TMN	≤ ± 0.05 % (please contact us for bearingless encoders)
Accuracy TRN	≤ ± 0.2 %
Reproducibility	≤ ± 0.02 %
Temperature drift	≤ 0.02°/K

CANOPEN/CANOPEN SAFETY SIL2 OVERVIEW OF SPECIFICATIONS

CiA DS301	CANopen Application Layer and Communication Profile, Version 4.2.0
CiA DS406	CANopen - Device Profile for Encoders, Version 4.1.0
CiA DS305	CANopen - Layer Setting Services and Protocol (LSS)
DIN EN 50325-5: 2016-06	2016-06 Industrial communication sub-system based on ISO 11898 (CAN) - Part 5: Functionally safe communication based on EN 50325-4.
CAN-Interface	according to ISO/DIS 11898
Address setting	over LMT/LSS or SDO
Terminating resistance	to be implemented separately (optionally: circuit board mounted)
Max. transmission length	30 m
Bootloader function	yes System prerequisites: <ul style="list-style-type: none"> ■ PCAN-USB adapter (www.peak-system.com) including USB cable for PC connection ■ MCANopen tester TWK software, hex file for updating ■ encoder connecting cable
Number of PDOs	2 Tx
Number of SRDOs	2 Tx (CANopen Safety SIL2)
PDO-Modes	sync, async, cyclic, acyclic
SRDO-Mode	cyclic (CANopen Safety SIL2)
Variables PDO-Mapping:	yes
Emergency Message	yes
Heartbeat	yes
No. of SDOs:	1 Rx/1 Tx
Device Profile	CiA DSP 406 Version 4.1.0

The profile details are described in detail in the user manual [TBN/TRN15469](#). The CRC calculation is carried out using the [CRC-Calculator](#) program, which can be provided to the customer on request.

* CW = increasing output value when shaft rotating clockwise
 ** CCW = increasing output value when shaft rotating anti-clockwise

TECHNICAL DATA

SYSTEM AND SAFETY

Duty cycle (rise time) supply voltage	500 ms (10 % to 90 %)
Information density	up to 10,000 messages/s
Storage cycle time	3 s per memory cycle
Setup Time	~ 2 s @ T ≥ +20 °C
Time between the detection of a fault and the output of the emergency message	100 ms (voltage supply) 5 s (RAM test, all individual bits ok) 2 s (ROM test (within setup time))
Safety standard	IEC 61508: 2017: Functional Safety of Electrical/Electronic/Programmable Electronic Safety-related Systems
EDS file	The EDS file is available on request

MECHANICAL DATA

Operating speed	max. 1.000 min ⁻¹ (with shaft sealing ring) max. 15.000 min ⁻¹ (with Nilosring/ bearingless)
Angular acceleration	10 ⁵ rad/s ² max.
Moment of inertia (rotor)	20 gcm ² (Ø ≥ 50 - design form with integrated bearing) 1 gcm ² (Ø 42 - design form with integrated bearing)
Operating torque	≤ 8 Ncm (design form with integrated bearing)
Starting torque	≤ 3 Ncm (design form with integrated bearing)
Permissible shaft load	Ø ≥ 50 - design form with integrated bearing 250 N axial, 250 N radial Ø 42 design form with integrated bearing 50 N axial, 50 N radial - standard, higher values optional
Bearing service life	≥ 10 ⁹ rotations* (for design form with integrated bearing))
Mass	TBN Ø 58: Aluminium approx. 0.3 kg, Steel approx. 0.4 kg TRN Ø 58: Aluminium approx. 0.5 kg, Steel approx. 0.7 kg TRN Ø 42: Aluminium approx. 0.3 kg, Stainless steel approx. 0.35 kg Weight specifications for the other constructions and bearingless designs on request.

ENVIRONMENTAL DATA

Working temperature range	- 40 °C to + 82 °C (Ø 78 for ATEX Zone 1/21, - 40 °C to + 70 °C)
Storage temperature range	- 20 °C to + 60 °C (due to packaging)
Resistance	To shock 250 m/s ² , 6 ms, je 100 x in 3 axes every 100x (higher values optional) DIN EN 60068-2-27 To vibration 100 m/s ² , 5 Hz ... 2000 Hz, in 1 h in 3 axes, (higher values optional) DIN EN 60068-2-6
Protection grade (DIN EN 60529)	Shaft side: IP66/ IP67 - shaft sealing ring, IP65 - Nilos ring (For higher degrees of protection up to IP68/ IP69K, please contact our technical con- tact persons)

* This value applies for maximum shaft load

TECHNICAL DATA

EMC STANDARDS

EN 61000-6-4:2006 + A1:2011	EMC Part 6-4: Generic standards-Emission standard for industrial environments
EN 61000-6-2:2005	EMC Part 6-2: Generic standards-Immunity for industrial environments
EN 61000-4-2:2009	EMC Part 4-2: Testing and measurement techniques - Electrostatic discharge immunity test
EN 61000-4-3:2006 A1:2008 + A2:2010	EMC Part 4-3: Testing and measurement techniques - Radiated, radio frequency. electromagnetic field immunity test
EN 61000-4-4:2004	EMC Part 4-4: Testing and measurement techniques - Electrical fast transient/burst immunity test
EN 61000-4-5:2006	EMC Part 4-5: Testing and measurement techniques - Surge immunity test
EN 61000-4-6:2009	EMC Part 4-6: Testing and measurement techniques - Immunity to conducted disturbances, induced by radio-frequency fields
EN 61000-4-8:2010	EMC Part 4-8: Testing and measurement techniques - Power frequency magnetic field immunity test. Power frequency magnetic field immunity test: 30 A/m, test criterion A (± 16 digit), 100 A/m, test criterion B
EN 61000-4-29:2000	EMC Part 4-8: Testing and measurement techniques - Voltage dips, short interruptions and voltage variations on d.c. input power port immunity tests
IEC 61326-3-2:2018	Electrical equipment for measurement, control and laboratory use - EMC requirements Part 3-2: Immunity for safety-related systems and for equipment intended to perform safety related functions (functional safety) - industrial applications with specified electromagnetic environment

SAFETY DATA TBN

Service life	20 years
HFT	0 Hardware fault tolerance
SFF	96,23% Safe failure fraction
DC	92,64% Diagnostic Coverage
PFH	6,48003 x10 ⁻⁸ h. Probability of dangerous Failure per hour

SAFETY DATA TRN

Service life	20 years
HFT	0 Hardware fault tolerance
SFF	96,27% Safe failure fraction
DC	92,95% Diagnostic Coverage
PFH	7,69932 x10 ⁻⁸ h. Probability of dangerous Failure per hour

SAFETY DATA TMN

To be determined

TECHNICAL DATA

BUS CONNECTION AS PER ISO/DIS 11898

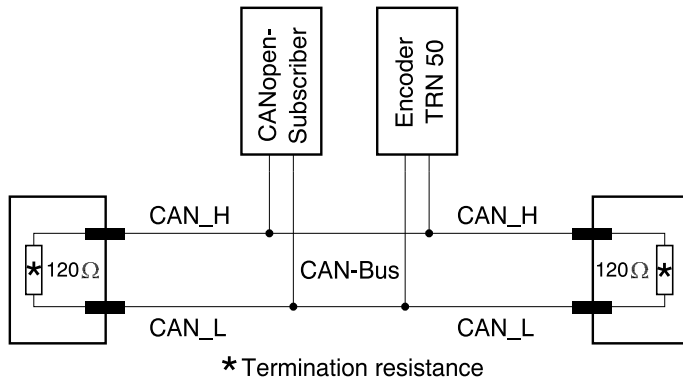

OUTPUT LEVEL AS PER ISO/DIS 11898

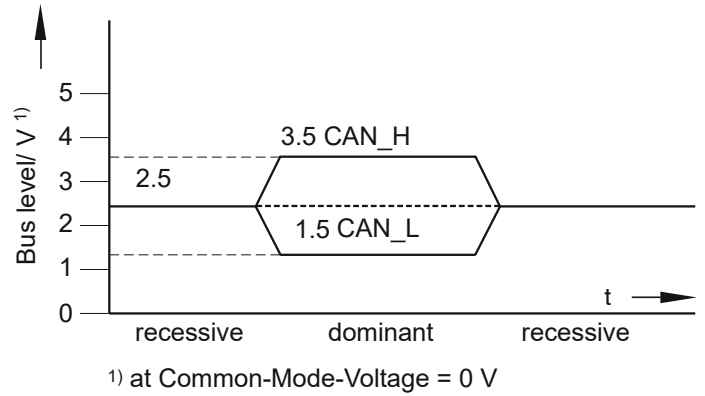

DATA PROFILE CANOPEN

PDO1/2 (position and speed)

PDO 1 / PDO 2

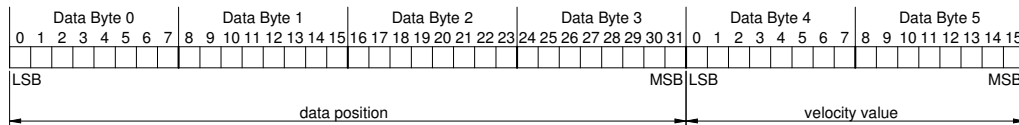

DATA PROFILE CANOPEN SAFETY SIL2

SRDO1 (safety position) – normal and bit-inverted

SRDO 1

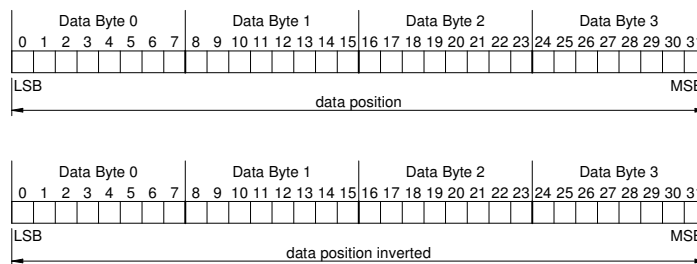

DATA PROFILE CANOPEN SAFETY SIL2

SRDO2 (safety speed) – normal and bit-inverted

SRDO 2

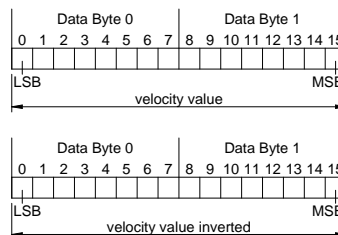

TECHNICAL DATA

PRINCIPAL CIRCUIT DIAGRAM TBN/ TMN AND TRN (CANOPEN SAFETY SHOWN)

MODEL: TBN/TMN...S4...SAFETY

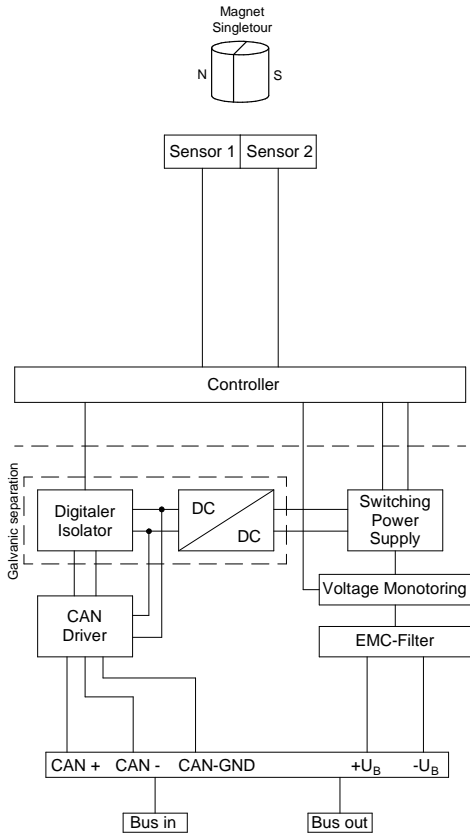

MODEL: TRN...S4...SAFETY

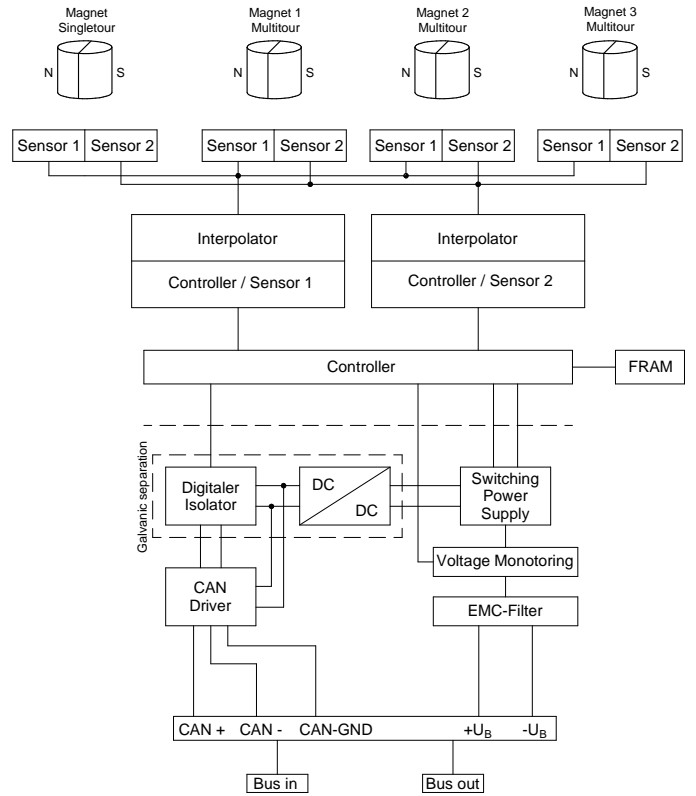

TECHNICAL DATA

SLEWING RING SOFTWARE 'S' FOR TRN SAFETY ENCODER

For applications in wind turbines, cranes, transport units, etc. it is desirable to emulate the function of a mechanical gearbox. For example, if the rotary encoder is coupled to the drive axle of a gearbox or if the position of a slewing ring is to be detected using a measuring gear with coupled rotary encoder.

Software version 'S' provides this function. The encoder is located on the fast gear axis (drive wheel) and calculates the position of the slow gear axis (output wheel) via the transmission ratio. The transmission ratio and the resolution of the output axis (digit per revolution) can be freely selected. The output code is consistent beyond the code range of the encoder, regardless of the selected transmission ratio. The transmission ratio can be even or odd.

The user does not have to evaluate the gear revolutions and can run through any number of gear periods in one direction. This means that non-reversing operation is possible.

The slew ring software manages a global offset secured by a CRC algorithm, which ensures that a full gear period is always available, even at the end of the encoder's code range. For the correct function of the module, the encoder may only be rotated a pre-determined number of revolutions (1024 to 2047 revolutions in each direction by default depending on the gear ratio) in a de-energised state. Please see Handbook [TXN 15469](#) for further details, especially "Safety Notes to slewing ring functionality for "(safety_)gear_configuration".

ENCODER OUTPUT

The output resolution can be customer specific ex-works or parameterized by the customer with the "(safety_)gear_configuration" CANopen Objects. Depending on the gear ratio different resolutions e.g. 1/100° (36000 steps/360° slewing ring rotation) or 1/1000° (360000 steps/360° slewing ring rotation) can be parameterized. For further details please refer to Handbook [TXN 15469](#).

value (for 36000 steps/360° of the slewing ring): 8738 [dez]

current slewing ring position: 87,38°

0° - Preset Position

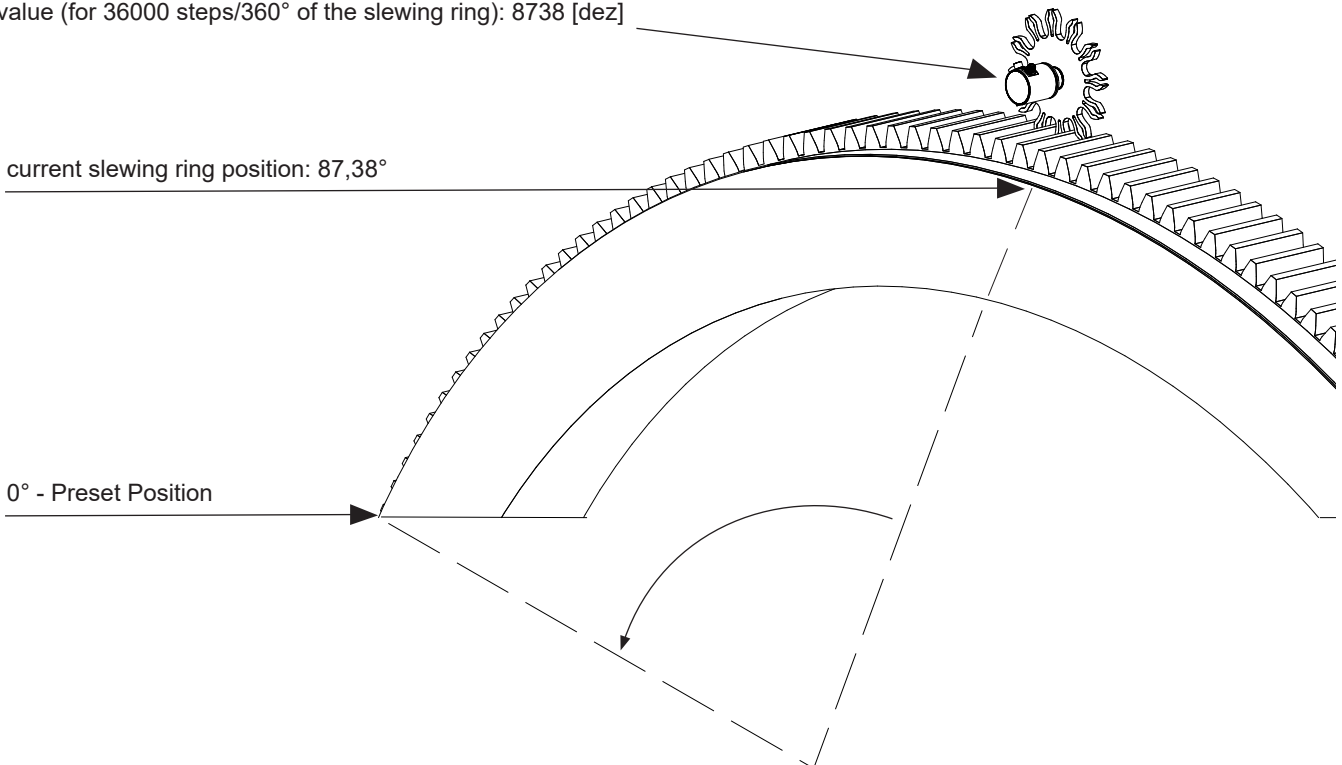

ELECTRICAL CONNECTION - PIN CONFIGURATION

ELECTRICAL CONNECTION

- TBN Ø 58 / TRN Ø 58
 - With connector M12x1, pin, 5-pin, A-coded
 - With 2 connectors M12x1, pin and socket, 5-pin, A-coded, Bus In and Bus Out
 - With 2 connectors M12x1, pin and socket, 5-pin, A-coded, Bus In and Bus Out
- For Ø 42, 55, 78 cable outlet, see drawings at the end of this document
- The connection assignment TYxxxxx is part of the scope of supply and is included with each device.
In order to reduce unnecessary paper consumption, this can be omitted for standard devices after consultation.

PIN DIAGRAM M12X1, 5-PIN, VIEW OF PLUG-IN SIDE AND ORIENTATION (STANDARD)

Socket, 5-pin, A-coded
Plug-in side

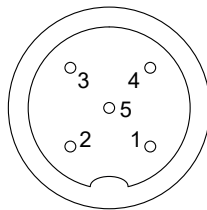

Pins, 5-pin, A-coded
Plug-in side

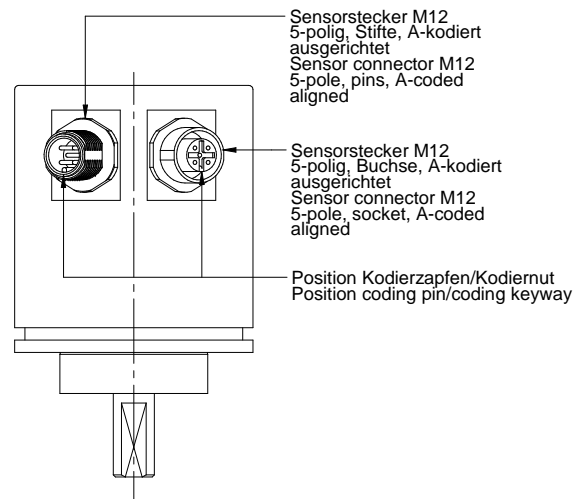
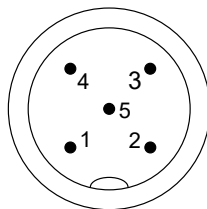

Note: The 5-pin M12x1 connector is used as standard. There are three different galvanic concepts for potential isolation (V1-V3) (see also page 9).

ELECTRICAL CONNECTION

GALVANIC POTENTIAL ISOLATION: -V_S, CAN_GND AND HOUSING/CABLE SHIELDING

The description of the different versions of galvanic potential (V1 to V3) relates exclusively to the interrelationships between the individual potentials (-V_S, CAN_GND and housing/cable shielding), i.e. whether or not they are galvanically connected. The connection assignment (TYxxxx) should be observed. This connection assignment is included with each device and a copy can be requested as needed.

V1: CAN_GND, -V_S AND HOUSING/CABLE SHIELDING GALVANICALLY ISOLATED

This version has complete galvanic isolation. The housing/cable shielding are galvanically isolated from -V_S and CAN_GND, and -V_S and CAN_GND are also galvanically isolated from one another. The cable shielding is galvanically connected to the housing via the connector housing

PIN	Function
1	CAN GND
2	Operating voltage + V _S
3	Operating voltage - V _S
4	CAN_H
5	CAN_L

V2: CAN_GND AND -V_S NOT GALVANICALLY ISOLATED, CABLE SHIELDING GALVANICALLY ISOLATED

This version has partial galvanic isolation: The housing/cable shielding are galvanically isolated from -V_S and CAN_GND. But: -V_S and CAN_GND are not galvanically isolated from one another. The cable shielding is assigned to pin 1.

PIN	Function
1	Shielding
2	Operating voltage + V _S
3	Operating voltage - V _S and CAN-GND
4	CAN_H
5	CAN_L

V3: CAN_GND, -V_S AND CABLE SHIELDING/HOUSING NOT GALVANICALLY ISOLATED

This version has no galvanic isolation: The housing/cable shielding are not galvanically isolated from -V_S and CAN_GND, and -V_S and CAN_GND are not galvanically isolated from one another.

PIN	Function
1	Shielding – short-circuited with PIN 3
2	Operating voltage + V _S
3	Operating voltage - V _S and CAN-GND, short-circuited with PIN 1
4	CAN_H
5	CAN_L

ORDER CODE FORMAT

TRN | **58 -** | **KP** | **A** | **16384** | **R** | **4096** | **S4** | **S1** | **V1** | **N** | **01** | **STANDARD VERSION**

TBN	Singleturn rotary encoder with CANopen-Interface		
TMN	Multiturn rotary encoder with electronic counter and CANopen-Interface		
TRN	Multiturn rotary encoder with mechanical gearbox and CANopen-Interface		
58	Design form	42 - 53 - 58 - 78 -	Design form Ø 42 mm Design form Ø 53 mm, standard KIT Encoder Design form Ø 58 mm (ATEX protection for zone 2/22 on request) Design form Ø 78 mm, Explosion-proof enclosure for Zone 1/21 TRX16360
KP	Flange and shaft	E K KF KP KZ S SN SP SR VP	Bearingless "KIT Encoder" with external magnet (standard design form 53, otherwise on request) Clamping flange, shaft Ø 10 mm with flattening Clamping flange, shaft Ø 10 mm with woodruff key Clamping flange, shaft Ø 10 mm with feather key Clamping flange, shaft for target wheel ZRS (see ZRS11877) Synchro flange, shaft Ø 6mm with flattening Synchro flange, clamping shaft Ø 12 mm with woodruff keyway for feather key Synchro flange, shaft Ø 10 mm with feather key Synchro flange, clamping shaft for Ø 12 mm for torque arm ZMS12939 Square flange, shaft Ø 10 mm with feather key (only for design 78)
A	Housing material	A B P S U V W Leave blank	Aluminium 3.2315 - (AlMgSi1) Burnished steel for shielding strong magnetic fields Plastic Stainless steel - 1.4305 (AISI 303) Stainless steel (1.4104) for shielding against strong magnetic fields (only available with an integral bearing). Stainless steel - 1.4404 (AISI 316L) or 1.4401 (AISI 316) for type 78 Magnetic stainless steel - 1.4521 (AISI 444) for shielding strong magnetic fields V4A (only on request, only bearing version) Without housing (plain PCB)
16384	Resolution in steps/360°	4096 ... 65536	12 bit ... 16 bit
R	Code	R S	Binary Slewing ring functionality (only model TRN)
4096	Measuring range	4096 18	Rotations [decimal] only TRN (mechanical gearbox) other measuring ranges on request 18 bit, corresponds to 262,144 revolutions, only TMN (electronic counter) other measuring ranges on request
S4	Profile	C3 M1 S4	Standard CANopen, Profile version 4.1.0 standard sensor interface Standard CANopen, Profile version 4.1.0 multi sensor interface CANopen Safety SIL2, Profile version 4.1.0
S1	Electrical connection Combine S, T, K or L and quantity	S T K L 1 2	Device connector M12, 5-polig, radial Device connector M12, 5-polig, axial Cable, 1m, radial (other lengths on request) Cable, 1m, axial (other lengths on request) 1 x Device connector or cable 2 x Device connector or cable (Bus In/Bus Out)
V1	Galvanic Isolation	V1 V2 V3	-V _S ≠ CAN_GND ≠ shielding/housing -V _S = CAN_GND ≠ shielding/housing -V _S = CAN_GND = shielding/housing
N	Output signal	N	CANopen-Interface
01	Electrical and mechanical versions*	01	Standard

* According to the datasheet, the basic (standard) versions are indicated by the number 01. Deviations are indicated by a version number and are documented at the factory.

ACCESSORIES (PLEASE NOTE THE SHAFT ENCODER VERSION)

MATING CONNECTORS (ORDER SEPARATELY)

Order number, Datasheet	Type	Design & wire fixing	Housing-material	Cable \varnothing & wire size	Shielding & IP grade
STK5GS56, –	M12-A 5-pole, female	Straight, screws	Brass, nickel-plated	6 – 8 mm $\leq 0.75 \text{ mm}^2$	On housing IP67
STK5GP90, –	M12-A 5-pole, male	Straight, screws	Brass, nickel-plated	6 – 8 mm $\leq 0.75 \text{ mm}^2$	On housing IP67
STK5WS58, –	M12-A 5-pole, female	Angled, screws	Brass, nickel-plated	6 – 8 mm $\leq 0.75 \text{ mm}^2$	On housing IP67
STK5WP102, –	M12-A 5-pole, male	Angled, screws	Brass, nickel-plated	6 – 8 mm $\leq 0.75 \text{ mm}^2$	On housing IP67
STK5GS107, –	M12-A 5-pole, female	Straight, screws	Stainless steel	5,5 – 8,6 mm $\leq 0.75 \text{ mm}^2$	On housing IP67
STK5GP106, –	M12-A 5-pole, male	Straight, screws	Stainless steel	5,5 – 8,6 mm $\leq 0.75 \text{ mm}^2$	On housing IP67

Please note: If angled mating connectors are used, please specify the position of the coding groove so that the device connectors can be aligned accordingly.

COUPLINGS

x and y: Bore diameter for shaft support

BKM 26 / x - y Play-free bellow coupling
Data sheet [11995](#)

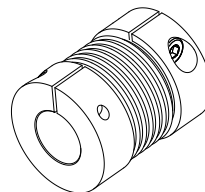

BKK 32 / x - y Play-free bellow coupling
Data sheet [11840](#)

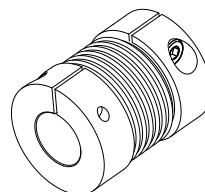

KK14S / x - y Play-free clamp coupling without groove
Data sheet [12301](#)

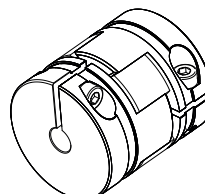

KK14N / x - y Play-free clamp coupling with groove
Data sheet [12301](#)

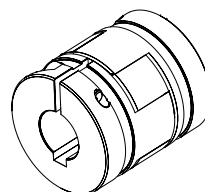

ACCESSORIES (SELECTION)

MOUNTING BRACKET

Mounting brackets for shaft encoder assembly
KL 662-S Data sheet [10111](#)

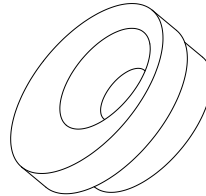

TORQUE SUPPORT

Torque support/stator coupling. Suitable for use as a shaft encoder bracket for the clamping shaft version, for the offsetting of radial and axial drive shaft play for Ø 58 mm shaft encoders
ZMS58 Data sheet [12939](#)

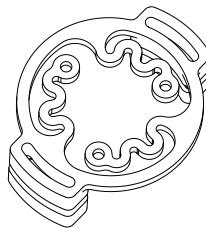

MEASURING WHEEL

Play-free measuring wheel ZRS for Ø 58 mm shaft encoders for live ring applications
ZRS Data sheet [11877](#)

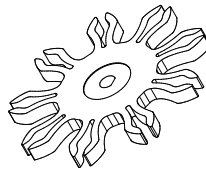

DOCUMENTATION

DOCUMENTATION, EDS FILE, ETC.

The following documents plus the EDS file, CRC calculation program and TWK CANopen tester can be found in the Internet under www.twk.de in the documentation area, model TRN/TBN.

- Data sheet [TXN14271](#)
- Manual [TXN15469](#)
- Certificate, TBN/TRN S4 [TXN15603](#)
- Installation instructions [AN16169](#)
- Safety Library (VDMA/Sistema) [Safety Library](#)
- Declaration of Conformity CE: [ZE12467](#), UKCA: [ZE16569](#)
- Reach compliant [QS15286](#)
- RoHS compliant [QS13284](#)
- Pin assignment TYxxxxx
 (enclosed with each device or on request, for series deliveries the pin assignment is no longer enclosed after customer consultation for environmental reasons)

- CRC checksum program for parameterisation www.twk.de/files/CRC-Calculator20.zip
- Specification CRC software [CRC14076](#)
- TWK CANopen-Tester www.twk.de/files/CANopenTest_2_39_1.zip

INSTALLATION DRAWINGS

DRAWINGS

Rotary encoder	Page	Note
TBN 42-S.....K1.....N01	14	Singleturn, Standard, Synchro flange
TRN 42-S.....K1.....N01	14	Multiturn, Standard, Synchro flange
TBN 42-S.....K1.....NXX	14	Singleturn, extra short version with cable, bolt circle Ø 32 mm, housing length 40 mm , with Nilos ring
TRN 42-S...S4K1.....NXX	15	Multiturn, extra short version with cable, housing length 54 mm , with Nilos ring
TBN/TMN 53-Ex.....T1(K1).....NXX	15	KIT Encoder Standard, axial cable output, (optional: radial cable output)
TBN/TMN 55-S.....K1.....NXX	16	Singleturn (multiturn counter), extra short version with cable, housing length 30 mm , with Nilos ring
TBN/TMN 58-K.....S1.....N01	16	Singleturn (multiturn counter), Standard, Clamping flange
TRN 58-K.....S1.....N01	17	Multiturn, Standard, Clamping flange
TRN 58-KZ.....S1.....N01	17	Multiturn, Standard, Clamping flange with gear shaft
TBN/TMN 58-S.....S1.....N01	17	Singleturn (multiturn counter), Standard, Synchro flange
TRN 58-S.....S1.....N01	18	Multiturn, Standard, Synchro flange
TRN 58-S.....K2.....NXX	18	Extra short multiturn safety version with two cables, housing length 50 mm
TBN/TMN 58-SR.....S1.....N01	19	Singleturn (multiturn counter), Standard with torque support (available separately)
TRN 58-SR.....S2.....N01	20	Multiturn, Standard with torque support (available separately)
T...N 78-KP.....S2.....NXX	21	Ex-protection zone 1/21 version

INSTALLATION DRAWINGS

MODEL E.G.: TBN42 - SX XXXXX R XX K1 VX N01

dimensions in mm

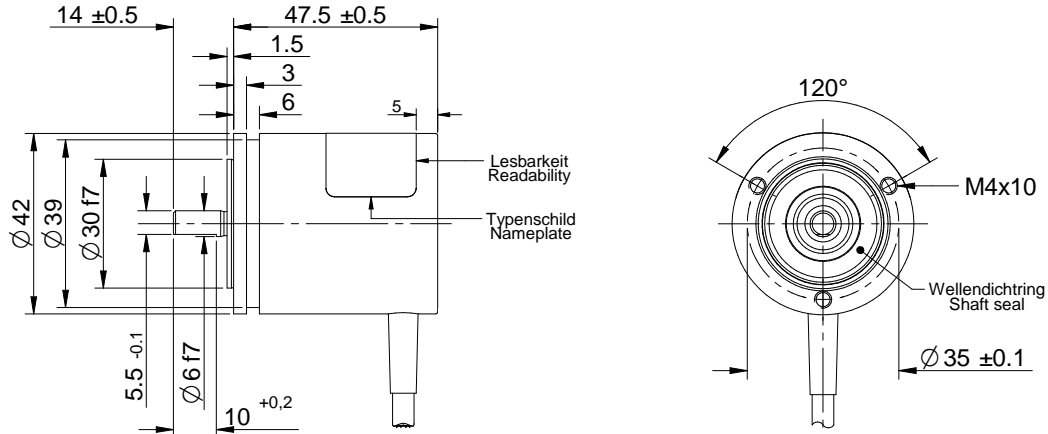

MODEL E.G.: TRN42 - SX XXXXX R 4096 XX K1 VX N01

dimensions in mm

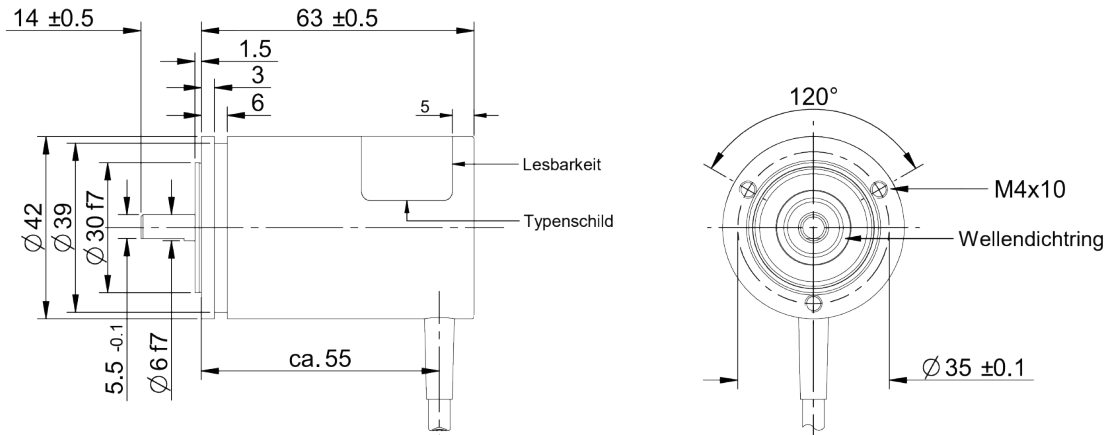

MODEL E.G.: TBN42 - SX XXXXX R XX K1 VX NXX

dimensions in mm

special variant short, not standard according to data sheet

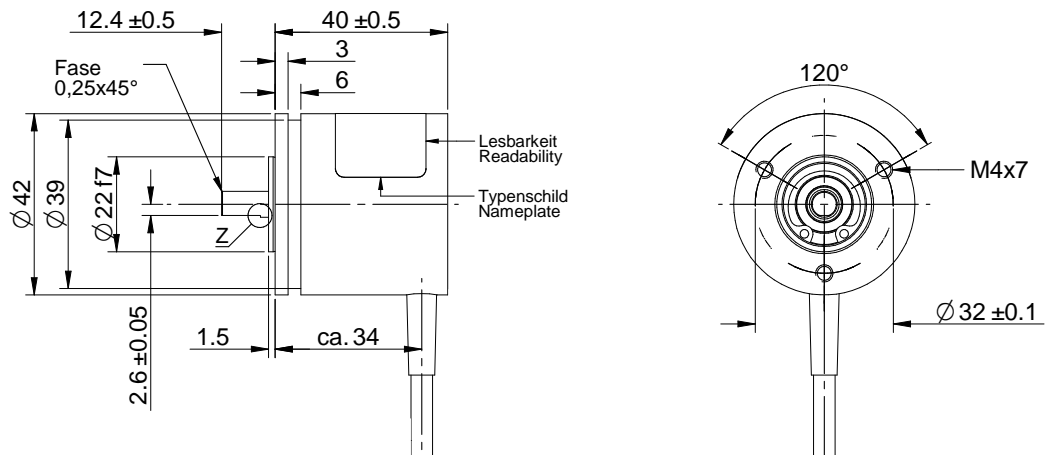

INSTALLATION DRAWINGS

MODEL E.G.: TRN42 - SV XXXXX R 4096 XX K1 VX NXX

dimensions in mm
special variant short, not standard according to data sheet

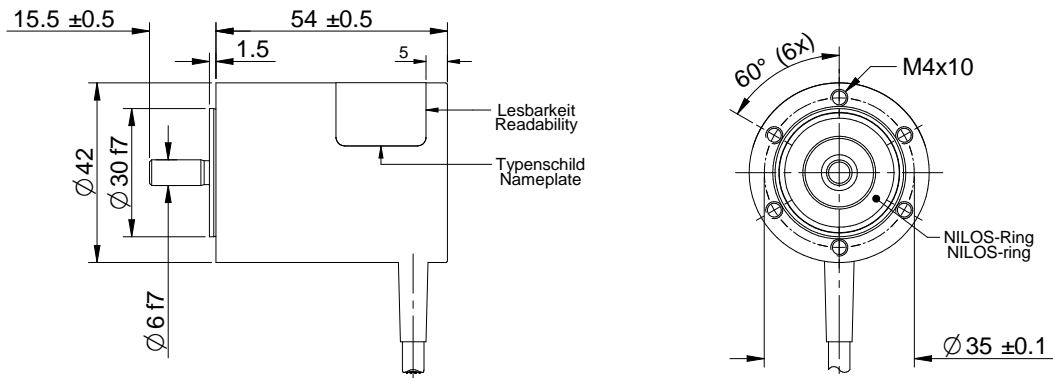

MODEL E.G.: TXN53-EX-T1(K1)V2NXXX

dimensions in mm

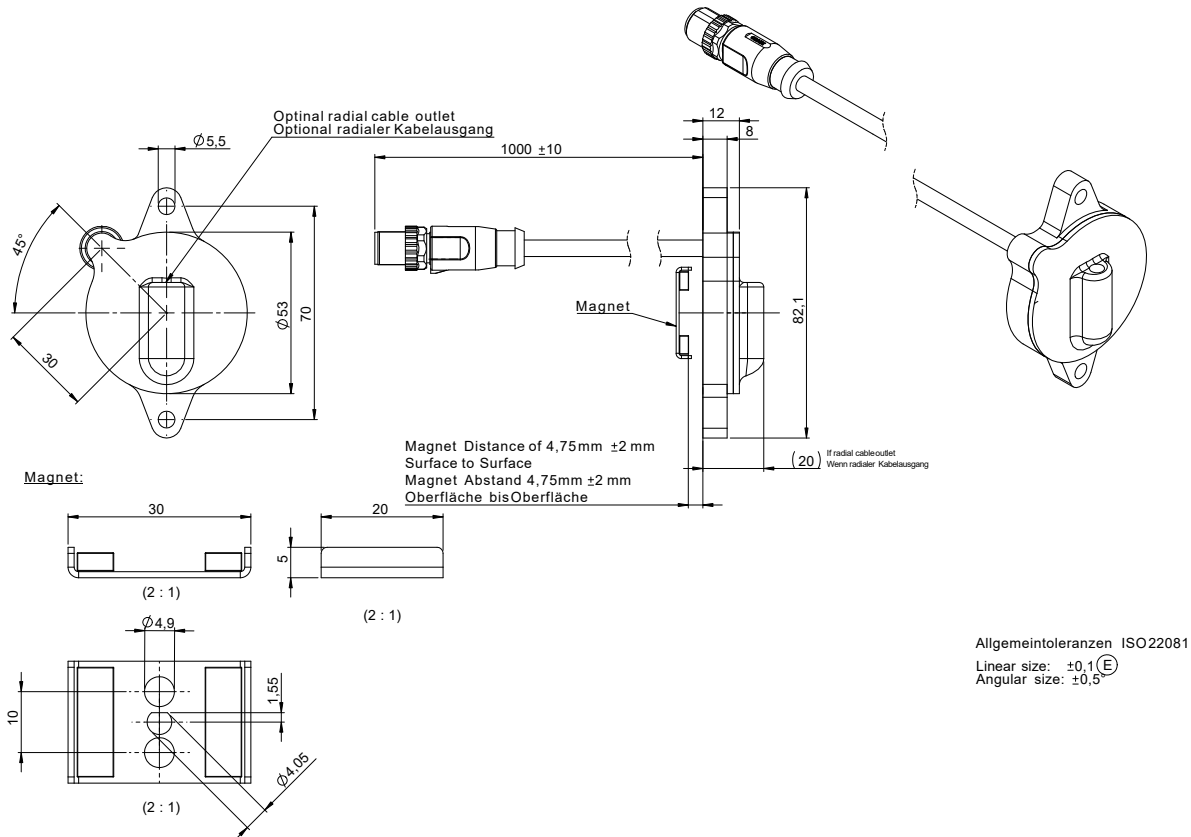

INSTALLATION DRAWINGS

MODEL E.G.: TBN/TMN55 - SX XXXXX R XX K1 VX NXX

dimensions in mm
 special variant short, not standard according to data sheet

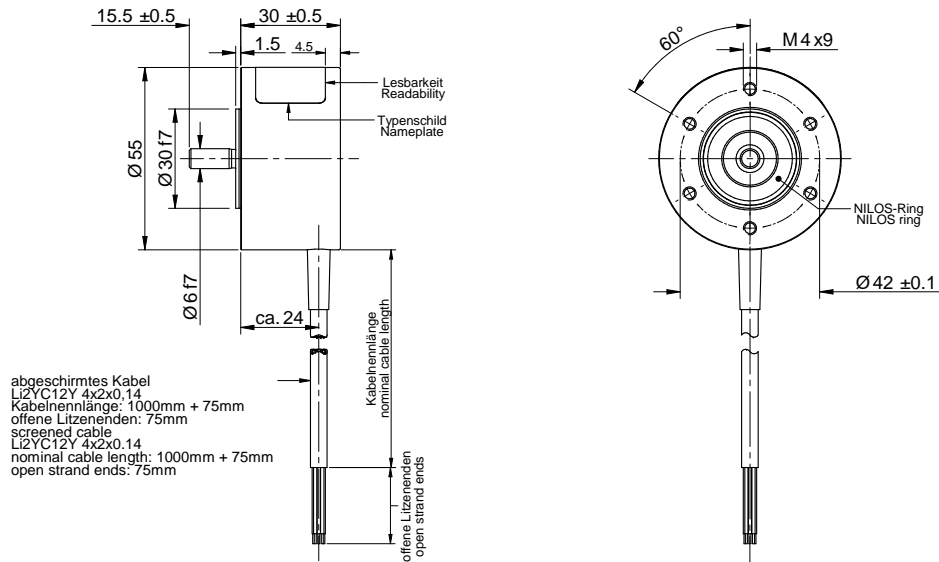

MODEL E.G.: TBN/TBN58 - KX XXXXX R XX S1 VX N01

dimensions in mm

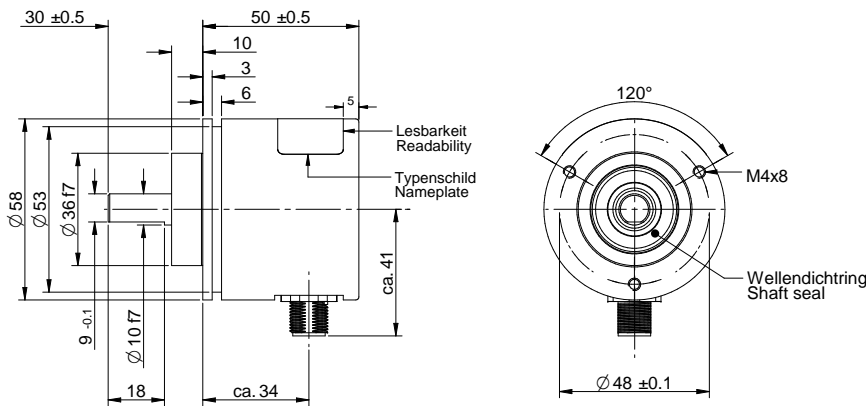

INSTALLATION DRAWINGS

MODEL E.G: TRN58 - KX XXXXX X 4096 XX S1 VX N01

dimensions in mm

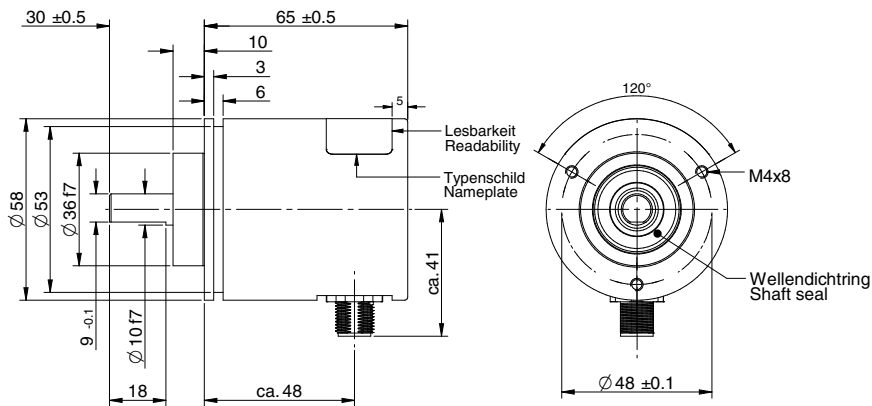

MODEL E.G.: TRN58 - KZX XXXXX X 4096 XX S2 VX N01

dimensions in mm

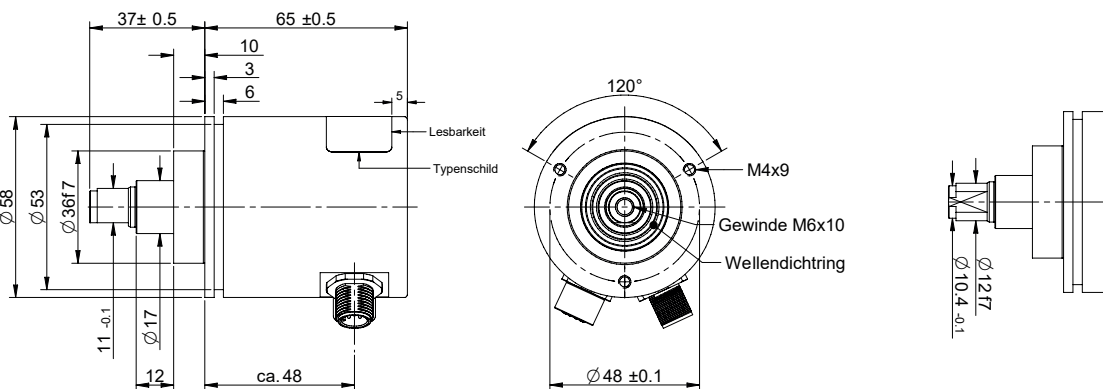

MODEL E.G.: TBN/TMN58 - SX XXXXX R XX S1 VX N01

dimensions in mm

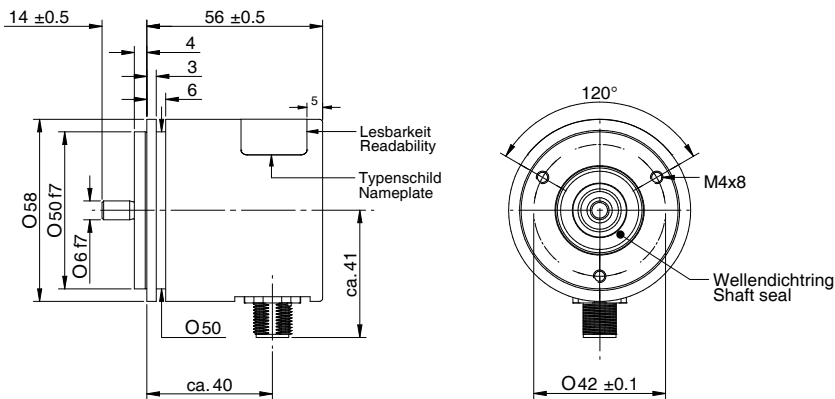

INSTALLATION DRAWINGS

MODEL E.G.: TRN58 - SX XXXXX X 4096 S4/C3 S1 VX N01

dimensions in mm

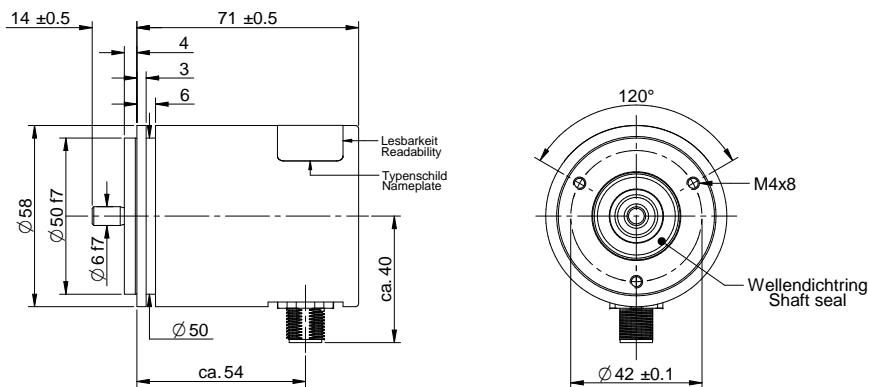

MODEL E.G.: TRN58 - SX XXXXX X 4096 XX K2 VX NXX

dimensions in mm - special variant short, not standard according to data sheet

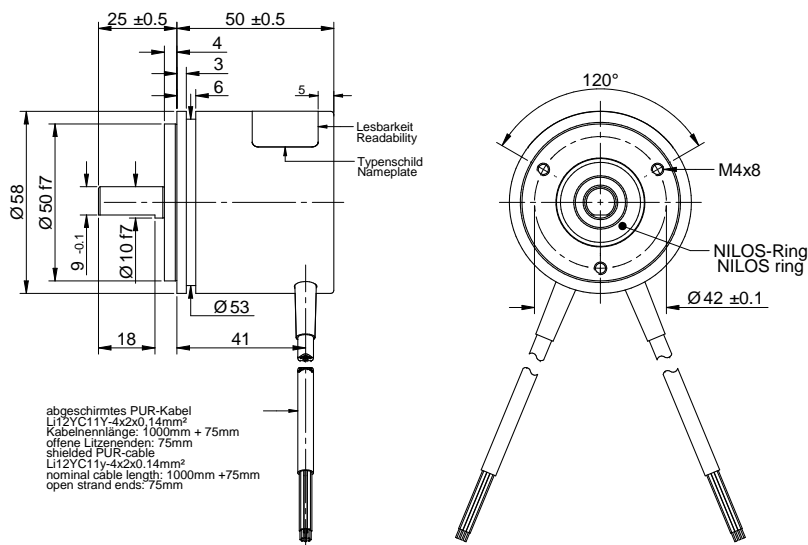

INSTALLATION DRAWINGS

MODEL E.G.: TBN/TMN58 - SRX XXXXX R XX S1 VX N01 UND ZMS58-S-H1-K01

dimensions in mm

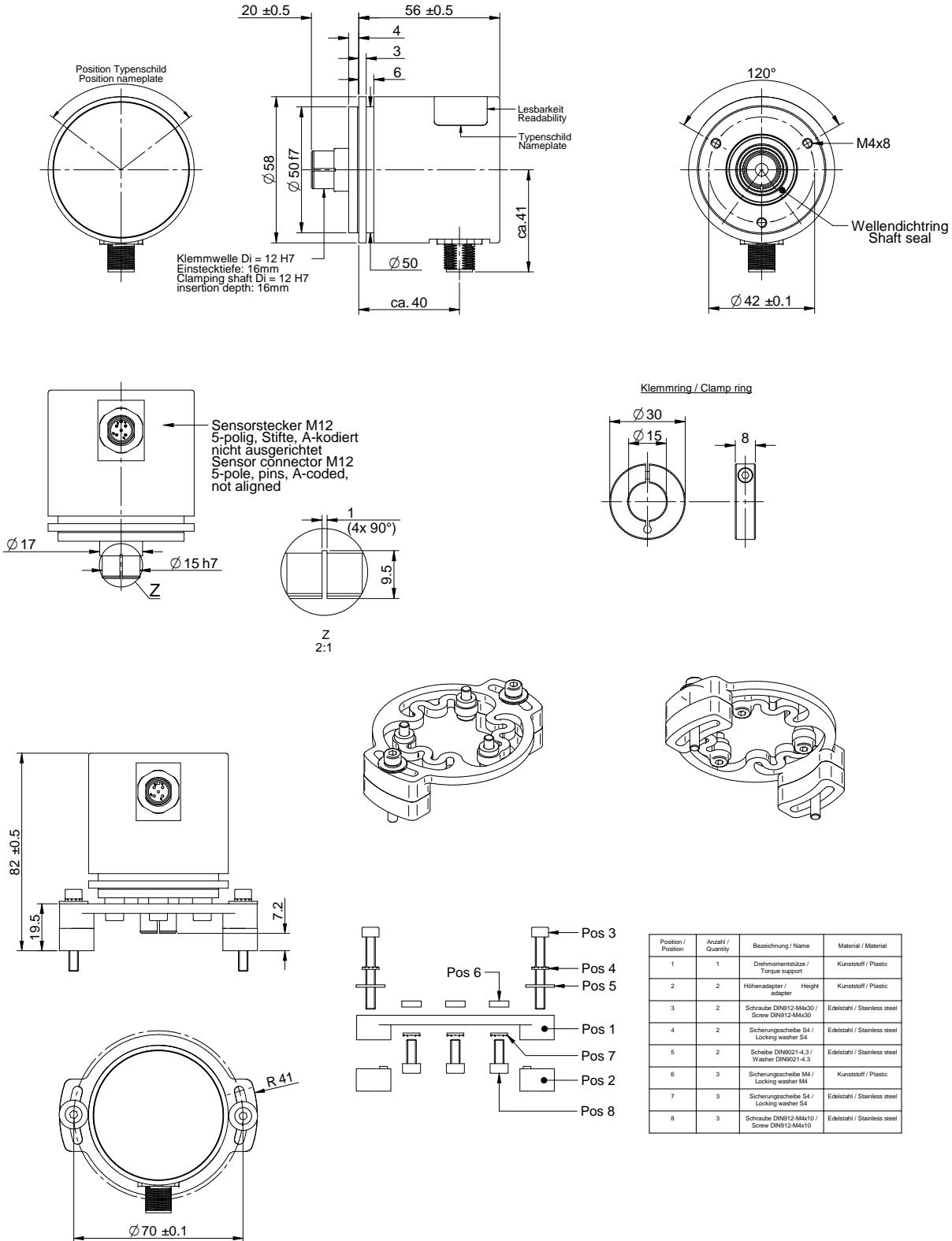

INSTALLATION DRAWINGS

MODEL E.G.: TRN58 - SRX XXXXX R 4096 XX S1 VX N01 UND ZMS58-S-H1-K01

dimensions in mm

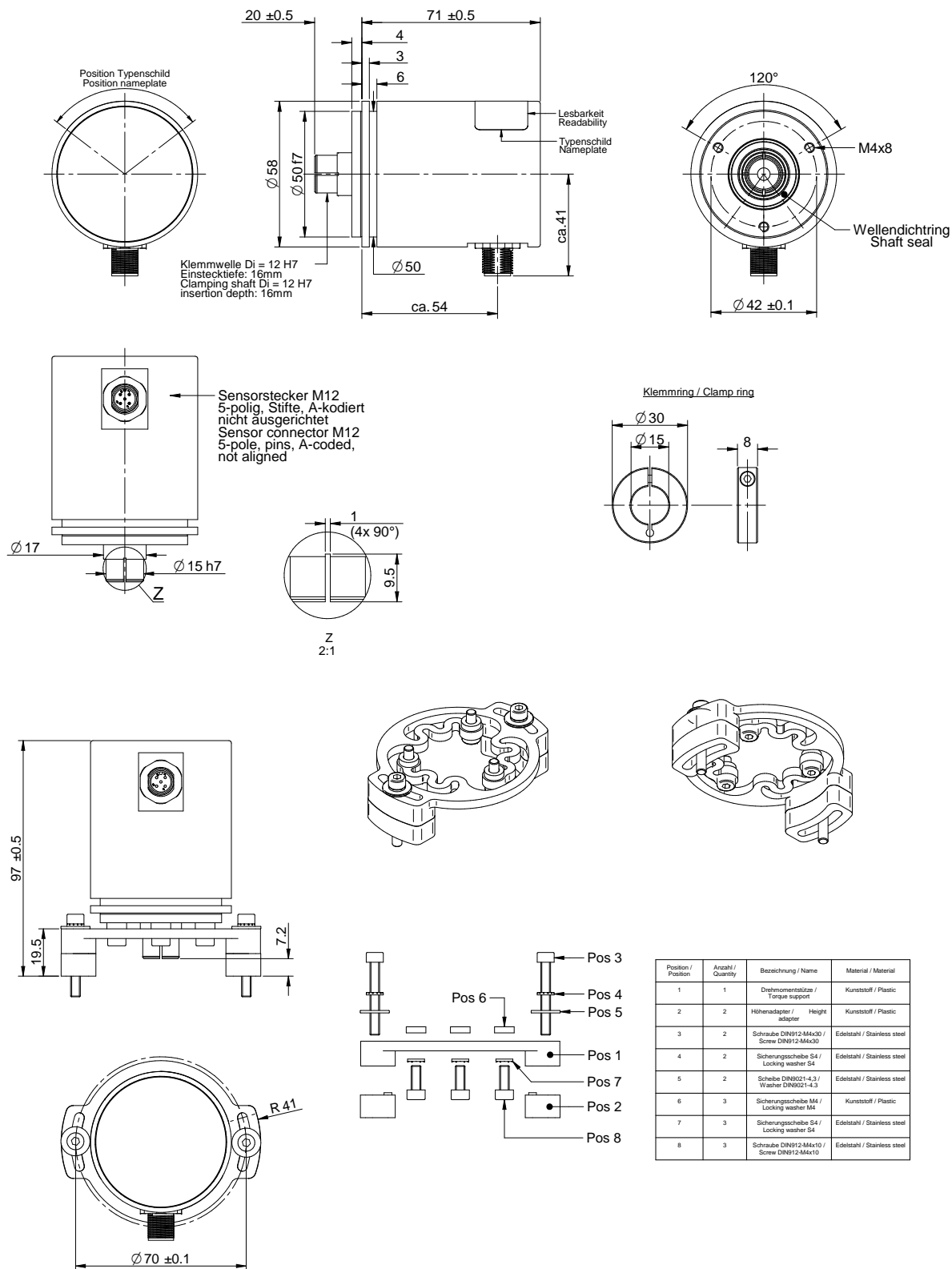

INSTALLATION DRAWINGS

MODEL E.G.: TRN/ TBN78 - KPX XXXXX X 4096 S4 K2 VX NXX

dimensions in mm
 ATEX Variant zone 1/21 and 2/22

