

Electro-magnetic Encoders

TBX 50 series Singleturn

Document no.: TBX 11294 JE
Date: 14.07.2021

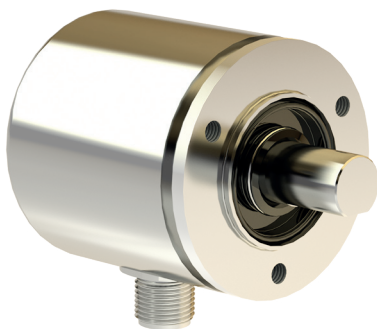

SSI

BiSS INTERFACE

CANopen®

ANALOGUE INCREMENTAL

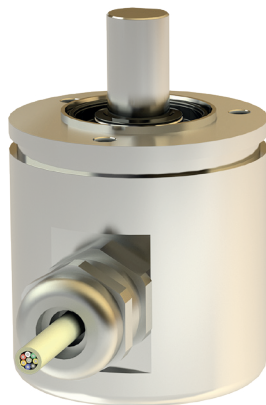

- Contactless rotary sensor, free of wear
- Compact, low-cost design for mechanical engineering especially for building machinery, underwater devices and food conditioning equipment
- Resolution: 4096 positions / 360° (12 Bits)
- With digital or analogue interfaces
- Case in aluminium (AlMgSi1) or stainless steel (1,4305/1,4404)
- Optional potting for shock and vibration protection
- Two - chamber construction to separate rotating components from electronic circuit
- Protection grades: IP 66 or IP 69K (option)
- Working temperature range: - 40 °C to + 85 °C
- Optionen:
 - TBN/S with CANopen Safety
 - Redundant systems
 - SIL2 (IEC61508)
 - Clamping shaft

Construction

Robust case with wall thickness of 5 mm either in seawater resistant aluminum or in stainless steel - shaft and ball bearings in stainless steel - rotating components with permanent magnet in front chamber - electronic circuit with ASIC and Hall elements and interface components fitted within main chamber, separated from rotating components by a metallic wall - optional potting against water jets (IP 69K) - electrical connections via round plug or lead exit.

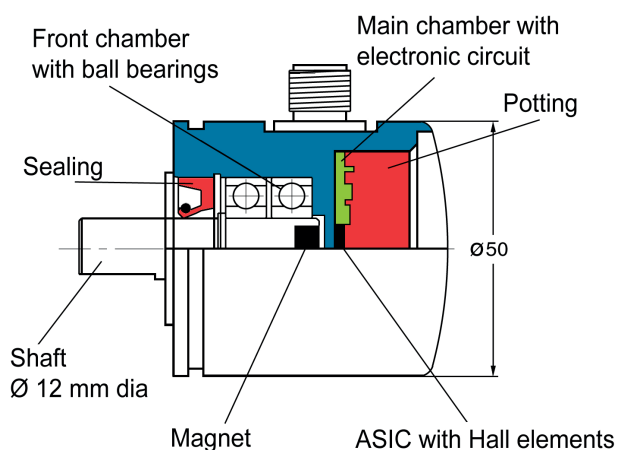

Electronic interfaces

- **Model TBA 50:** Analogue (page 3)
- **Model TBB 50:** Bi-direktional serial BiSS (page 5)
- **Model TBE 50:** Synchronus-seriel SSI (page 7)
- **Model TBI 50:** Incremental (page 10)
- **Model TBN 50:** CANopen (page 12)
- **Model TBN/S3:** CANopen Safety
(Data sheet: TBN 11709
Manual: TBN 11748)
- **New: Modell TBN/TRN/S4: CANopen Safety**
(Data sheet: TBN/TRN 14271;
Manual: TBN/TRN 15469)

- The connection data are supplied with each item.

Dimensions, materials and accessories: Page 15

Electro-magnetic Encoders **TBX 50**

General technical data

General technical data

Electrical data of all models

- Sensor system: ASIC with Hall elements
- Accuracy: $\pm 0.25\%$, optional $\pm 0.1\%$ (with reference to 360°)
 - for analogue models: $\pm 0.3\%$, optional $\pm 0.15\%$ (with reference to 360°)
- Reproducibility: $\pm 0.02\%$ (with reference to 360°)
- Temperature drift: typ. 0.1% (with reference to 360°) over the entire temperature range
 - for analogue models: typ. $0.01\% / K$
- EMC-standards
 - Interference immunity: EN 61000-6-2
 - Interference emission: EN 61000-6-4

Mechanical data of all models

- Operating speed: 1,000 rpm max.
(10,000 rpm / optional)
- Angular acceleration: 10^5 rad/s^2 max.
- Inertial mass (rotor): 20 gcm^2
- Operating torque: $\leq 8 \text{ Ncm}$ at 500 rpm
- Wind-up torque: $\leq 4 \text{ Ncm}$
- Permissible shaft loads: 250 N (axial and radial)
- Bearing life expectancy: 10^9 revolutions
- Mass: 0.350 kg approx.

Environmental data of all models

- Operating temperature: $-40\text{ }^\circ\text{C}$ to $+85\text{ }^\circ\text{C}$
- Storage temperature: $-20\text{ }^\circ\text{C}$ to $+60\text{ }^\circ\text{C}$ (dependant on packing materials)
- Resistance to shock: 500 m/s^2 ; 11 ms
(DIN EN 60068-2-27)
- Resistance to vibration: 10 Hz ... 2000 Hz ; 500 m/s^2
(DIN EN 60068-2-6)
- Protection grades: IP 66
(DIN EN 60529) IP 69K (with optional potting of main chamber)

Electro-magnetic Encoders **TBA 50**

Analogue outputs 0-20 mA, 4-20 mA, 0-10 VDC or ± 10 VDC

ANALOGUE

Technical data

In order to record mechanical variables such as angles, rotary movements or positions, the contactless electromagnetic sensor system is extended with a 12-bit (with 360° measuring angle) D/A converter so that the measured variable is available as an analogue signal from 0 (4) to 20 mA, 0 to 10 V or ± 10 VDC. - As standard, the encoders are designed for a measuring angle of 360°. At the request of the customer, other measuring angles can also be set with the specified output signals in the factory. A symmetrical overflow / underflow value is output outside of the measuring range (see characteristic curve).

Characteristic: Measuring angle 262° as an example

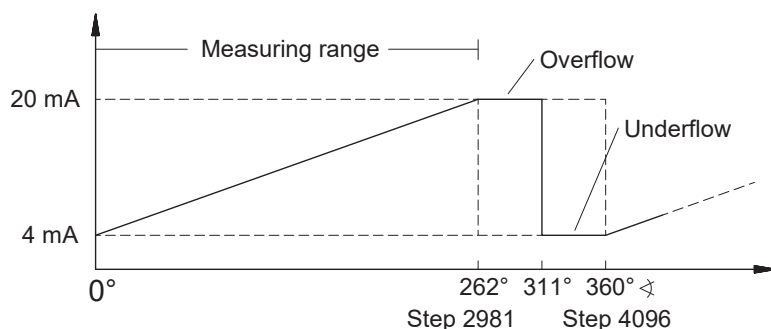

Electrical data

- Resolution at 360°: 12 Bits
- Measuring range: 360° (90° or 180° at option)
(other ranges upon request)
- Output signals:
 - A: 0 to 20 mA
 - B: 4 to 20 mA
 - C: 0 to 10 VDC
 - D: ± 10 VDC
- Signal sense: CW (CCW at option)
- Zero shift: At option
- Supply voltage range: 20 to 28 VDC (output A,B,C)
 ± 13 to ± 16 VDC (output D)
- Supply current: 50 mA typ. / 60 mA max.
- Linearity: ± 0.25 % option ± 0.1 %
- Repeatability: ± 0.02 %
- Temperature drift: < 0.01 % / ° K / typ.

Current output accuracy

- at starting point
 - 0 mA 0 mA ± 50 μ A
 - 4 mA 4 mA ± 50 μ A
- at end point 20 mA: 20 mA ± 50 μ A
- Load resistance: 0 to 500 Ω at $V_s = 20$ to 28 VDC

Voltage output accuracy

- at starting point 0 V:
 - 0 V + 0.1 V (output 0 - 10 V)
 - 0 V ± 25 mV (output ± 10 V)
- at end point 10 V:
 - 10 V ± 25 mV
 - ± 10 V ± 50 mV
- Output current: 5 mA max. When load resistance
> 2 k Ω (short circuit proof)

Electro-magnetic Encoders **TBA 50**

Model TBA 50: Analogue outputs 0-20 mA, 4-20 mA, 0-10 VDC or ± 10 VDC

Technical data

Prinzipschaltbild

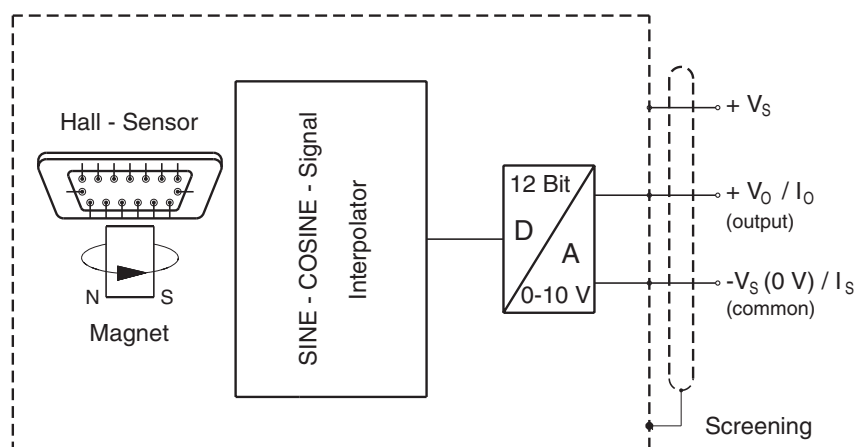

Note to Teach in functionality (Programmable)

For applications, which require the change of the zero position, the ending position, the change of the signal curve or the setting of the preset the TBA 50 can be designed with the Multi-Functional-Pins (analogy to the TRA 50, see data sheet TRX 11820).

The version number is on all output signals "100".

The additional multi-function pin is an M12 connector, 8 pin required respectively two additional conductors (wires) at the cable output.

Order code format

TBA	50	-	S	A	360	W	S	A	01
-----	----	---	---	---	-----	---	---	---	----

Electrical and mechanical variants*

- 01 Standard
- 100 Programmable version (Teach in)

Output signals:

- A 0 - 20 mA
- B 4 - 20 mA
- C 0 - 10 VCD
- D ± 10 VCD

Electrical connections:

- S Connector M12x1 **
- K 1 m lead **

Signal sense:

- W CW
- C CCW (optional)

Measuring range:

360 max. 360°

Case material:

- A Aluminium**
- S Stainless steel**

Flange:

- S Synchro flange

Design:

50 Diameter 50 mm

Model:

TBA **Analogue output**

* The basic versions in accordance with the data sheet bear the code number 01. Variations from the basic version are indicated with a consecutive number and are documented in our works.

** Case in aluminium with M12x1 (4 pins) connector, case in stainless steel with lead (1m) and D-Sub plug without hood (for test purposes only).

Electro-magnetic Encoders TBB 50 - BISS-Interface
Bidirectional Serial Interface - 12 Bit / 360°



Technical data

Function

BiSS is a serial sensor interface protocol for synchronous, fast and safe readout of sensor data, as well as for bidirectional access to the sensor registers. The interface is hardware-compatible with the *SSI* - interface and has two or more unidirectional lines. A system consists of a controller (master) and one to seven sensor (slave), which can be in a serial or semiparallel connection. For either type of connection the 'MA' line, originating from the master, is connected to all slaves. With the serial connection of the subscribers an input (SLI) at the sensor (connected to the output of the predecessor) enables a read of data from this sensor and, as a result, also the bus operation with several subscribers. The master successively receives the data of upto 7 slaves.

Electrical data

- Supply voltage range: + 11 VDC to + 28 VDC
- Supply current: 50 mA typ. / 80 mA max.
- Resolution (standard): 4096 positions / 360° (12 Bits) (13 Bits under development)
- Output code: Nat. binary (Gray optional)
- Code sense: CW (CCW optional)
- Output / input: Differential data output data input to RS 422/485
- Clock rate: 10 MHz max.

Block diagram

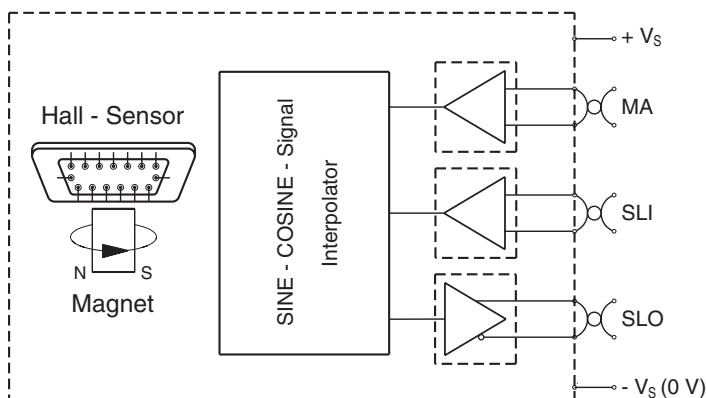

Timing diagram *BiSS* - Sensor modus

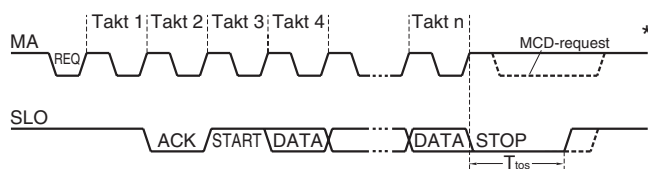

* Multicycle data - request

***BiSS* transmission format**

Res	Mode	Error	CRC	T1	T2	T3	T4 ... T16	T17	T18	T19	T20	T21	T22	T23	T24	T25	T26 ... T29	T30	Txx
12 bit	BiSS	x	x	1	Ack	Start	S11 ... S0	E1	E0	C4	C3	C2	C1	C0	MCD	Stop			
														P ..					
		Example		1	0	1								0	0				...

Electro-magnetic Encoders **TBA 50 TBB 50** Bidirectional Serial Interface - 12 Bit / 360°

Technical data

Serial subscriber connection

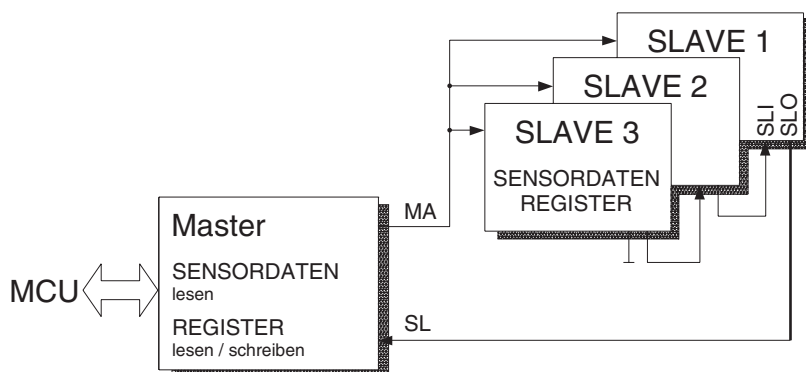

The *BiSS* data format

can be made available via www.biss-interface.de

Order code format

TBB	50	-	S	A	4096	R	S	B	01
-----	----	---	---	---	------	---	---	---	----

Electrical and mechanical variants*

01 Standard

Interface:

B *BiSS*

Electrical connections:

K 1 m lead**

S Connector M12x1**

Code:

R Nat. binary

Resolution:

4096 positions / 360°

Case material:

A Aluminium**

S Stainless steel**

Flange:

S Synchro flange

Design:

50 Diameter \varnothing 50 mm

Model:

TBB ***BiSS***-Interface

* The basic versions in accordance with the data sheet bear the code number 01. Variations from the basic version are indicated with a consecutive number and are documented in our works.

** Case in aluminium with M12x1 (4 pins) connector, case in stainless steel with lead (1m) and D-Sub plug without hood (for test purposes only).

Electro-magnetic Encoders **TBE 50**

Synchronous Serial Interface - 12 Bit / 360°

SSI

Technical data

Function

The absolute angle information derived by the encoder is converted into serial information by an internal parallel-serial converter and then transmitted to a receiving electronic circuit in synchronism with a clock. Important advantages are : Low number of data lines and high reliability.

Electrical data

■ Supply voltage range:	+ 11 VDC to + 28 VDC
■ Supply current:	50 mA typ. / 80 mA max.
■ Resolution (standard):	4096 positions / 360° (12 Bits) (13 Bits under development)
■ Output code:	Nat. binary (Gray optional)
■ Code sense:	CW (CCW optional)
■ Serial output:	Differential data output to RS 422
■ Clock input:	Differential data input via opto-coupler to RS 422
■ Monoflop time:	16 ± 10 µs (standard)
■ Clock rate:	1 MHz max.

Maximum data transmission rate

The data rate is defined by the following factors:

- Clock frequency 1 MHz max up to 40 meters connection line
- Delay time of the overall electronics (between 40 and 150 meters)

$$t_{GV} = t_C + 2t_K + t_E$$

t_{GV} : Total delay time

t_C : Delay time of the encoder electronics, e. g. ≤ 300 ns

t_K : Delay time of lead, depending on type and length, e. g. speed 6.5 ns/m

t_E : Delay time of receiving electronics, e. g. 150 ns

Admitting a security gap of 50 ns between the periods of clock t_T and the delay time of the overall electronics t_{GV} the result is shown as follows:

$$t_T = 500 \text{ ns} + 2t_K$$

- To RS422 specification starting at 150 m approximately

The opposite diagram is based on the above data.

Diagram: Cable length in meter as f (Frequenz)

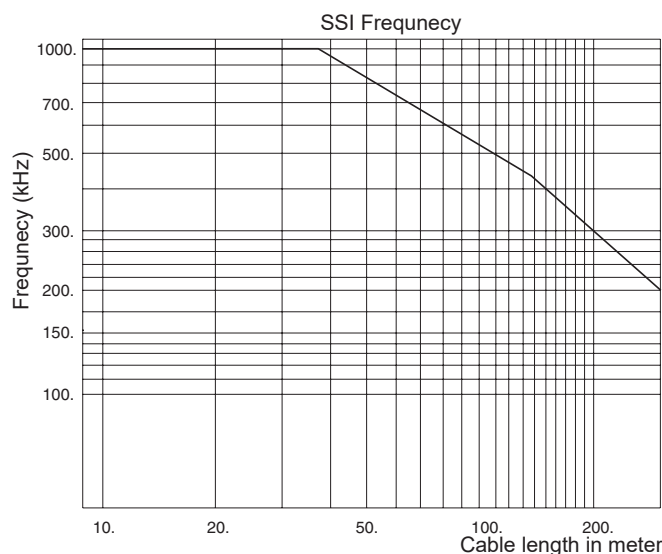

Electro-magnetic Encoders TBE 50
Synchronous Serial Interface - 12 Bit / 360°

Technical data

Block diagram

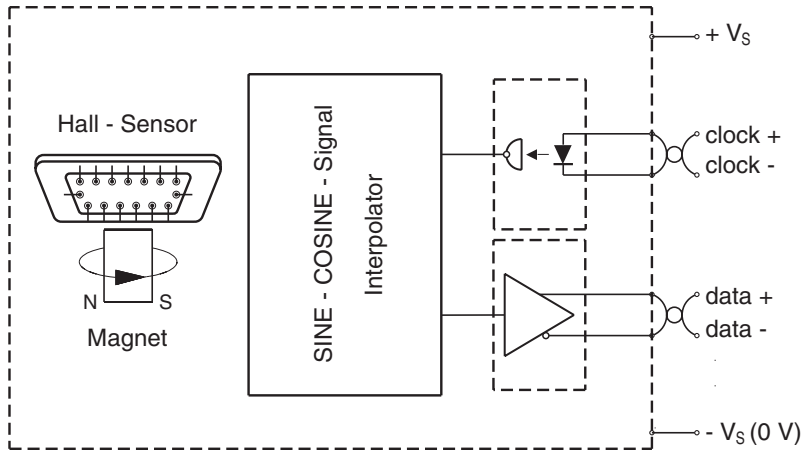

Interface profile SS/ - 13 Bits nat. binary

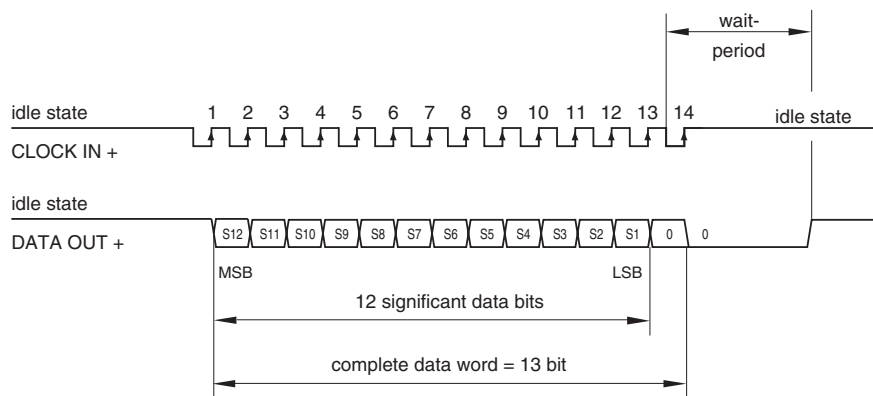

Electro-magnetic Encoders **TBE 50** Synchronous Serial Interface - 12 Bit / 360°

Order code format

TBE	50	-	S	S	4096	R	K	E	01
-----	----	---	---	---	------	---	---	---	----

Electrical and mechanical variants*

01 Standard

Interface:

E SS/

Electrical connections:

K 1m lead**

S Connector M12x1**

Code:

R Nat. binary

G Gray (optional)

Resolution:

4096 positions / 360°

Case material:

S Stainless steel**

A Aluminium**

Flange:

S Synchro flange

Design:

50 Diameter \varnothing 50 mm

Model:

TBE **SS/Interface**

* The basic versions in accordance with the data sheet bear the code number 01. Variations from the basic version are indicated with a consecutive number and are documented in our works.

** Case in aluminium with M12x1 (4 pins) connector, case in stainless steel with lead (1m) and D-Sub plug without hood (for test purposes only).

Electro-magnetic incremental encoder TBI 50
Incremental output 512 counts / rev.

INCREMENTAL

Technical data

Electrical data

- Number of counts: 512 (standard)
- Outputs: Tracks A, B and zero plus nversions
- form of signals: Square (Duty cycle 1:1)

- Other numbers of counts at option

1	10	32	80	200	500
2	16	40	100	250	512
4	20	50	125	256	
8	25	64	128	400	

Block diagram

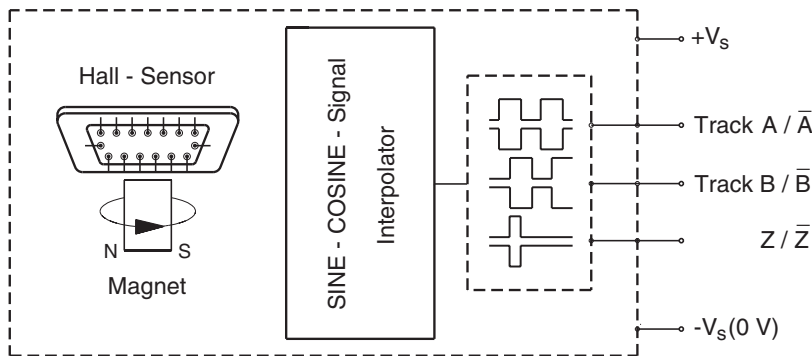

Signal output when CW turning (view on shaft)

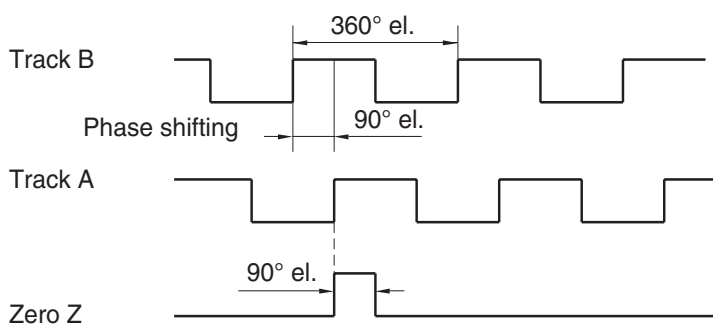

Elektro-magnetische Impulsgeber **TBI 50** Inkremental-Ausgang 1024 Imp / U

Technical data

Signal data

Signal code	D	T*	U
Supply voltage range V_s	11 to 28 VDC	5 VDC \pm 5 %	11 to 28 VDC
Signal current I_A	20 mA	20 mA	5 mA
Signal level (high)	$V_s - 3$ VDC	> 2,8 VDC	> 2.8 VDC
Signal level (low)	< 5 VDC	< 0,5 VDC	< 0.5 VDC
Max. pulse frequency	max. 250 kHz		
Pulse rate	1:1 \pm 30 %		
Phase shift	90° \pm 30°		
Length of zero pulse	90° (others upon request)		
Turning sense	CW (standard)		

* compatible to RS 422

Order code format

TBI	50	-	S	S	1024	K	D	01
------------	-----------	----------	----------	----------	-------------	----------	----------	-----------

Electrical and mechanical variants

01 Standard

Output signals (nominal):

D $U_B = 24$ V und $U_A = 24$ V

T $U_B = 5$ V und $U_A = 5$ V

U $U_B = 24$ V und $U_A = 5$ V

Electrical connections

K 1m lead**

S Connector M12x1**

Pulse:

1024 counts / rev.

Case material:

S Stainless steel**

A Aluminium**

Flange:

S Synchro flange

Design:

50 Diameter \varnothing 50 mm

Model:

TBI Incremental output

* The basic versions in accordance with the data sheet bear the code number 01. Variations from the basic version are indicated with a consecutive number and are documented in our works.

** Case in aluminium with M12x1 (4 pins) connector, case in stainless steel with lead (1m) and D-Sub plug without hood (for test purposes only).

Electro-magnetic Encoders **TBN 50**

CANopen interface - 12 Bits / 360°

Technical data

Electrical data

To CANopen Application Layer and Communication Profile, CiA Draft Standard 301, Version 4.1 and to "Device Profile for Encoders CiA Draft Standard Proposal 406 Version 3.0" und CANopen Layer setting Services and Protocol (LSS), CiA DSP 305.

- Supply voltage range: + 11 VDC to + 28 VDC
- Supply current: 50 mA typ. / 80 mA max.
- Resolution: 4096 positions / 360° (12Bits) (13 Bits under development)
- Output code: Nat. binary
- Code sense: CW / CCW
- Reference value: 0 - (total capacity less 1)
- CAN-interface: to ISO/DIS 11898
- Adressing: via SDO / LSS
- Termination resistance: by separate implementation
- Max. transmission length: 200 m

* No galvanic isolation between power supply and bus (see CiA DS301)

CANopen Features

- NMT Master: no
- NMT-Slave: yes
- Maximum Boot up: no
- Minimum Boot up: yes
- COB ID Distribution: Default, SDO
- Node ID Distribution: via Index 2000 oder LSS
- No of PDOs: 2 Tx
- PDO-Modes: sync, async, cyclic, acyclic
- Variables PDO-Mapping: no
- Emergency Message: yes
- Heartbeat: yes
- No. of SDOs: 1 Rx / 1 Tx
- Device Profile: CiA DSP 406 Version 3.0

For detailed description of the CANopen profile pl. refer to application manual TBN 11308.

Block diagram

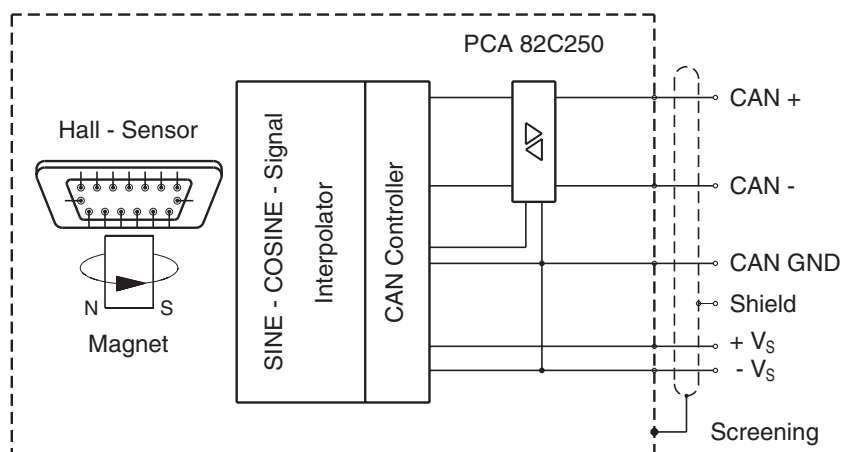

Technical data

Bus configuration to ISO / DIS 11898

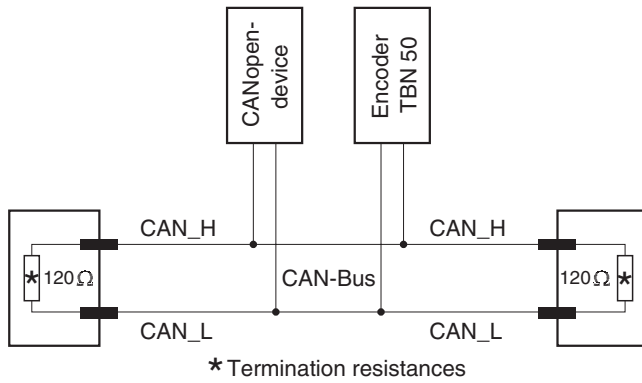

Data profile CANopen

PDO 1

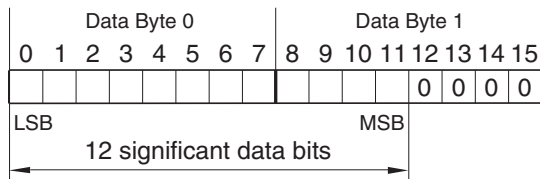

- **CANopen Safety (SIL 2 certified): TBN/S3 model** is described in the data sheet 11709 TBN and TBN 11748 in the user manual.

Electro-magnetic Encoders **TBN 50** CANopen Interface - 12 Bit / 360°

Order code format

TBN	50	-	S	A	4096	R	C2	S	N	01
-----	----	---	---	---	------	---	----	---	---	----

Electrical and mechanical variants*

01 Standard

Interface:

N CANopen

Electrical connections:

S Connector M12x1**

K 1m lead**

Profile:

C2 CANopen to CiA DS 406 Revision 3.0

Code sense:

R Nat. binary

Resolution:

4096 positions / 360°

Case material:

S Stainless steel**

A Aluminium**

Flange:

S Synchro flange

Design:

50 Diameter \varnothing 50 mm

TBN CANopen-Interface

* The basic versions in accordance with the data sheet bear the code number 01. Variations from the basic version are indicated with a consecutive number and are documented in our works.

** Case in aluminium with M12x1 (4 pins) connector, case in stainless steel with lead (1m) and D-Sub plug without hood (for test purposes only).

■ **Model TBN/TRN/S4, CANopen Safety:** Data sheet: TBN/TRN 14271,
Manual: TBN/TRN 15469

Electro-magnetic Encoders **TBX 50**

Installation drawing

Dimensions in mm

Case in aluminium with connector M12x1 (Version A)

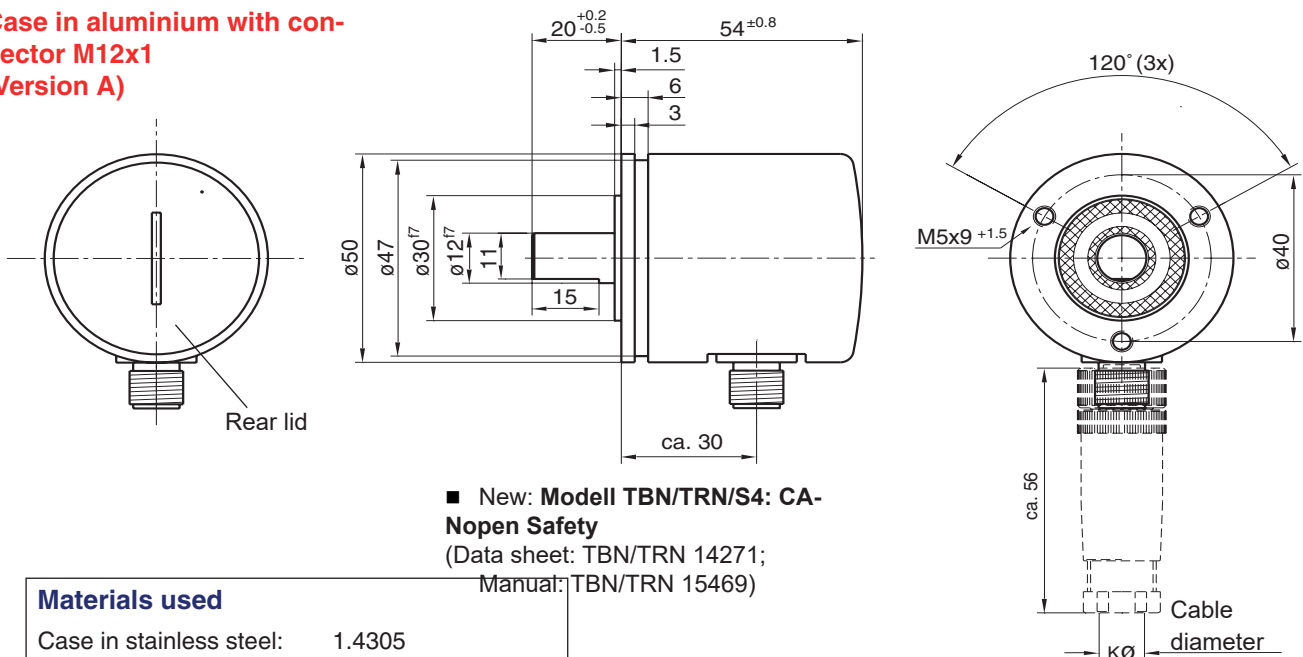

■ New: Modell TBN/TRN/S4: CA-Nopen Safety
(Data sheet: TBN/TRN 14271;
Manual: TBN/TRN 15469)

Materials used	
Case in stainless steel:	1.4305
Shaft in stainless steel:	1.4305
Rear lid:	polyamid / aluminium
Lead outlet:	1.4305
Shaft packing seal:	NBR
Taroidal sealing rings:	NBR

Case in stainless steel with lead exit (Version S)

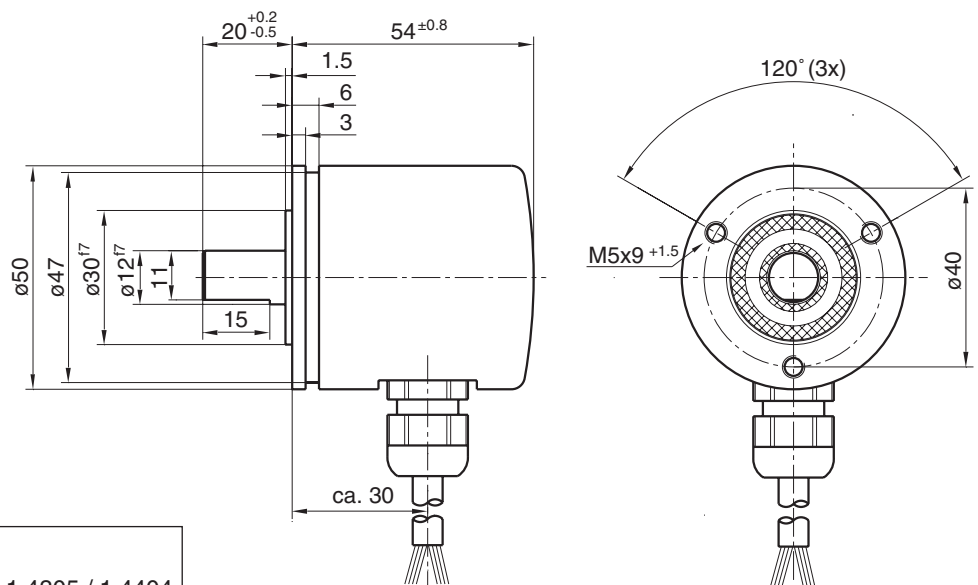

Materials used	
Case in stainless steel:	1.4305 / 1.4404
Shaft in stainless steel:	1.4305
Rear lid:	polyamid
Lead outlet:	1.4305
Shaft packing seal:	NBR
Taroidal sealing rings:	NBR

Accessories

Counter plug, straight, series **M12x1** (to be ordered separately)

Model	No. of pins	Material of case		K Ø (mm)
		Plastic ¹⁾	Metal ²⁾	
TBE 50	8	STK 8GS 53	STK 8GS 54	6 - 8
TBB 50	8	STK 8GS 53	STK 8GS 54	6 - 8
TBI 50	8	STK 8GS 53	STK 8GS 54	6 - 8
TBN 50	8	STK 8GS 53	STK 8GS 54	6 - 8
	(5) ³⁾	(STK 5GS 55)	(STK 5GS 56)	(4 - 6)
TBA 50	4	STK 4GS 59	STK 4GS 60	4 - 6
	4	STK 4WS 61	angled	4 - 6
	8	STK 8GS 53	STK 8GS 54	6 - 8

¹⁾ screen on pin
²⁾ screen on case
³⁾ at option

Contact arrangement **M12 x1**

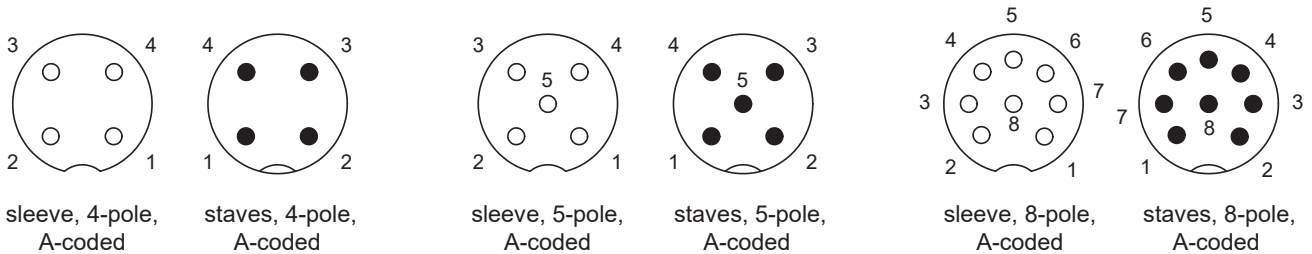

Play-free bellows coupling **BKK 32 / x - y**

x and y: Bore diameter for shaft support

See data sheet [BKK 11840](#)

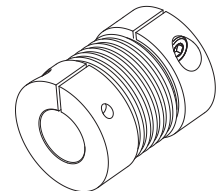

Play-free clamp coupling **KK14S / x - y**

x and y: Bore diameter for shaft support

See data sheet [KK 12301](#)

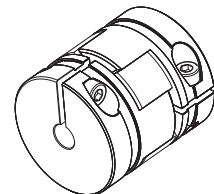

Mounting brackets **KL 66-2-S**

Mounting brackets for shaft encoder assembly.

See data sheet [MZ 10111](#)

