



TBA50

- **Robust design for demanding environmental conditions e. g. cranes and construction machinery**
- **Wear-free magnetic Sensor system**
- **Measuring ranges:**
TBA: 360°
TRA: 1,474,560° (4096 revolutions x 360°)
- **Protection grade IP65 / IP67 (IP69K option)**
- **Options:**
Redundant design (datasheet [TBA/TRA15241](#))
EX-protection versions for zone 2/22

ANALOGUE



KEY INFORMATION OVERVIEW

DESIGN & FUNCTION

Robust housing (wall thickness up to 5 mm) manufactured from seawater-proof aluminium (AlMgSi1 - 3.2315) or stainless steel (1.4305 or 1.4404).

Shaft fitted with ball bearings hold the magnet for measuring the angular position of the shaft and the multiturn drive gear for absolute revolution measurement.

The measuring ranges are:

- TBA: 360° = 1 rotation
- TRA: 1,474,560° = 4096 rotations

Design form in Ø 42, Ø 50, Ø 58 mm diameter (other diameters available for customer specific applications).

Magnetic sensor system for position measurement.

Electrical connection via connector M12-A, 4-pole (TBA), 8-pole (TBA-x100 and TRA) or via cable.

FEATURES INTERFACE

The rotary encoder has an analogue interface. The D/A converter has a resolution of 12 bits.

Analogue Signal outputs:

- 0 (4) to 20 mA or
- 0 to 10 VDC or
- ± 10 VDC

The output signal can be configured and referenced via by means of two multi-function pins (MFP). Standard adjusted range is 3600°.

Via the MFPs the following functions can be addressed:

- set zero point
- set end value
- set preset value (middle of the measuring range)
- code sense (CW or CCW).

Also, the default values can be restored.

The gradient of the signal output can be adjusted by using the functions set zero point and set end value.

TECHNICAL DATA

ELECTRICAL DATA

Sensor system	Magnetic
Operating voltage	18 to 28 VDC (Output: A, B, C) ± 13 to ± 16 VDC (Output: D) protected against polarity reversal, short-circuit proof
Power consumption	TBA: < 1 W TRA: < 1.5 W
Measuring range	TBA: 360° TRA: 1,474,560° (4096 revolutions x 360°, Default adjustment 3600°)
D/A-Converter	12 Bit
Code sense	CW* or CCW* (adjustable)
Accuracy	TBA: ± 0.15 % of 1 revolution typ. TRA: ± 0.3 % of 1 revolution typ.
Repeatability	± 0.02 % of 1 revolution typ.
Temperature drift	< 0.01 % / K of 1 revolution typ.

ELECTRICAL OUTPUT DATA

Current output	A: 0 to 20 mA B: 4 to 20 mA
Load resistance for A, B	0 ... 500 Ω
Voltage output	C: 0 to 10 VDC D: ± 10 VDC
Output current for C, D	max. 5 mA correspond to a load resistance of ≥ 2 k Ω , short-circuit proof

MECHANICAL DATA

Operating speed	max. 1000 rpm (shaft sealing ring), max. 10,000 rpm (Nilos ring)
Angle acceleration	10 ⁵ rad/s ² max.
Moment of inertia (Rotor)	$\varnothing 50, 58$: ~20 gcm ² $\varnothing 42$: ~1 gcm ²
Permanent shaft load	$\varnothing 50, 58$: 250 N axial, 250 N radial $\varnothing 42$: 50 N axial, 50 N radial
Bearing service live	$\geq 10^9$ revolutions**
Weight	TBA $\varnothing 58$: Aluminium approx. 0.3 kg, Stainless steel approx. 0.4 kg TRA $\varnothing 58$: Aluminium approx. 0.5 kg, Stainless steel approx. 0.7 kg

ENVIRONMENTAL DATA

Operating temperature range	- 40 °C to + 85 °C
Storage temperature range	- 20 °C to + 60 °C (depending on packaging)
Resistance	To Shock 250 m/s ² , 6 ms, 100 x each in 3 axes (higher values optional, e.g. 5000 m/s ²), DIN EN 60068-2-27 To Vibration 100 m/s ² , 5 Hz ... 2 kHz, 1 h in 3 axes (higher values optional e.g. 1000 m/s ²), DIN EN 60068-2-6
EMC-standards	DIN EN 61 000 - 6 - 2 Immision (Burst/ESD/...) DIN EN 61 000 - 6 - 4 Emission
Protection grade (DIN EN 60529)	Shaft side. IP66 - Shaft sealing ring, IP65 - Nilos ring Housing IP67, Option: IP69K (with potting)

EXPLOSION-PROOF

Zone 2 and zone 22 Realisation in standard housing with cable output (on request)

*) CW = Increasing output values when viewing the clockwise rotating shaft (CCW: counterclockwise)
**) This value applies for max. shaft load

PRODUCT CHARACTERISTICS

MEASURING RANGES

The singleturn encoder TBA has a standard measuring range of 360°. The measuring range can be adjusted in the factory and is specified by the customer through the order code (see [page 7](#)).

The multiturn encoder TRA has a maximal measuring range of 1,474,560° (360° x 4096 revolutions). The standard setting is 3600° (10 revolutions). The region outside the measuring range is symmetrically split into an over- and underflow value in the signal output (see characteristic curve 1). On request, customer specific signal outputs or outputs without over-/underflow are feasible ex works.

With the teach-in functionality (see [MFPs](#)) the encoder can be programmed customer specific, e.g. to 4096 revolutions or other values.

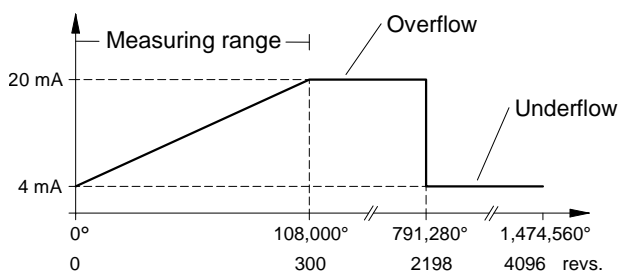

Characteristic curve 1: Measuring range 108,000° respectively 300 revolutions as an example (Output B)

	Parameter	TBA	TRA
	Maximum measuring range	360°	1,474,560°
Default values (ex works *)	Measuring range	360°	3600°
	Preset value	180°	1800°
	Code sense	CW	CW

* Other values on request.

For simple and fast programming and operation please use the *Analogue Hand Programming Device* model PMA-05 (see datasheet [PMA11443](#)).

PRODUCT CHARACTERISTICS

ADJUSTMENT VIA MULTI-FUNCTIONAL PINS FOR TRA AND TBA (TBA: ONLY FOR VARIANT 100)

The customer specific parameters 'zero point', 'end value', 'preset value', 'code sense' and 'set default values' can be set via two Multi-functional pins 'MFP0' and 'MFP1'. The input circuit is E1 (see [page 5](#)). The logical levels are '0': 0 VDC or '1': 24 VDC (=V_S).

With the functions 'set zero point' and 'set end value' the gradient of the signal output can be changed.

Table for multi-functional pins (MFP)			
Function	MFP 0	MFP 1	Remark
Set zero point	1	0	Set pin MFP 0 to logical 1 for ~4 s.
Set end value	0	1	Set pin MFP 1 to logical 1 for ~4 s.
Set default value	1	1	Simultaneously set pins MFP 0 and MFP 1 to logical 1 for ~4 s. The default setting is restored.
Changing code sense CW/CCW	1 0	0 1	Attention: Shaft must not be moved during this process (tolerance ~2°)! Set pin MFP 0 to logical 1 for ~4 s. After a pause of at least 0.5 s: Set pin MFP 1 to logical 1 for ~4 s.
Set preset value (middle of measuring range)	1 1	0 0	Attention: Shaft must not be moved during this process (tolerance ~2°)! Set pin MFP 0 to logical 1 for ~4 s. After a pause of at least 0.5 s: Set again MFP 0 to logical 1 for ~4 s.
Normal operation	0	0	

Note:

- If you can not find the measuring range by turning the shaft please set preset value via the MFPs. Then the encoder sets the middle of the measuring range. It is possible that the output signal is in the Over/Underflow area.
- The zero point and end value of the measuring range need to be separated by at least 2.5°. It is not possible to set lower values.

TIMING DIAGRAMS FOR THE MFP SETTINGS

■ **Set MFP 0 or MFP 1 once**

Set zero point (MFP 0)
Set end value (MFP 1)

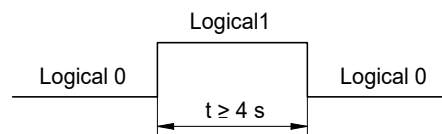

■ **Set MFP 0 and/or MFP 1 twice with the same shaft position**

Set preset value (2 x MFP 0)
Change the code sense (MFP 0 - MFP 1)

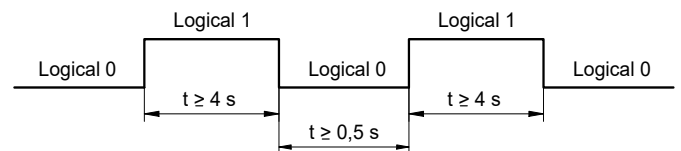

■ **Set MFP 0 or MFP 1 simultaneously**

Set default values
Time difference between MFP 0 and MFP 1 ≤ 0.25 s

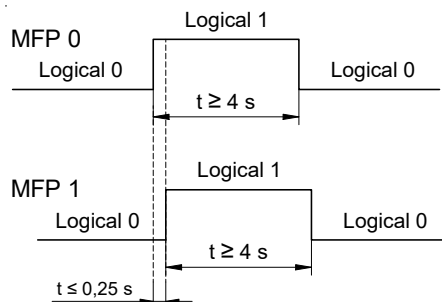

PRODUCT CHARACTERISTICS

INPUT CIRCUIT FOR INPUT E1 (MULTI-FUNCTIONAL PINS MFPS)

Input E1 active "high"

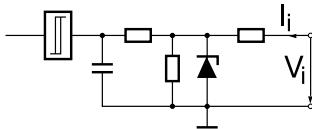

Log 0 < 5 V or not connected
Log 1 = 11 ... Vs
E1 specification

OUTPUT CIRCUIT

Output A

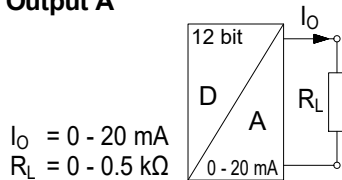

Output B

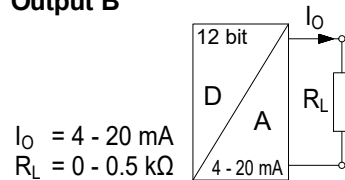

Output C

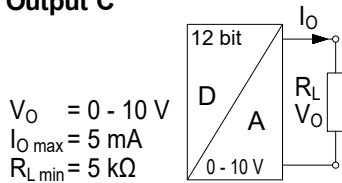

Output D

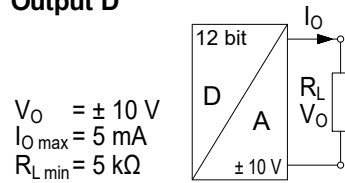

TECHNICAL DATA

PRINCIPLE CIRCUIT DIAGRAM

MODEL TBA

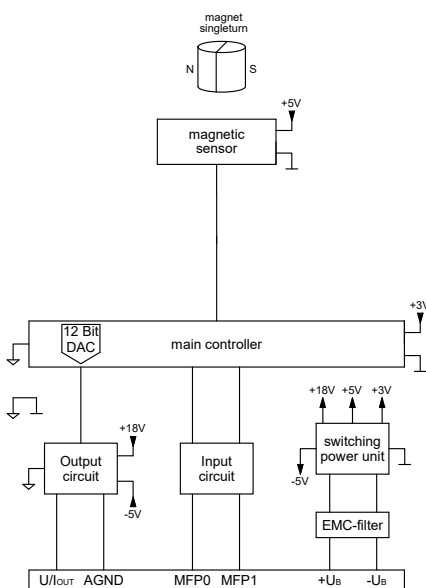

MODEL TRA

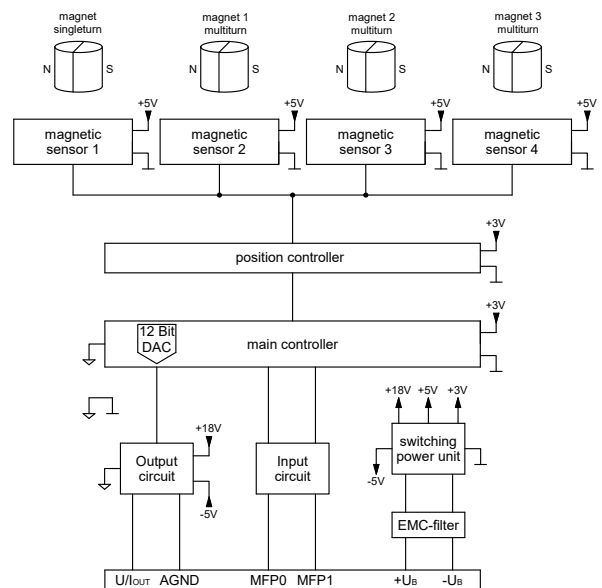

ELECTRICAL CONNECTION - PINOUT

ELECTRICAL CONNECTION

Singleturn:

TBA Ø 58, 50: M12x1, Pin, 4-pole, A-coded or radial cable, 4-wire

TBA Ø 42: Radial cable, 4-wire

TBA variant 100: M12x1, Pin, 8-pole, A-coded or radial cable, 8-wire

Multiturn:

TRA Ø 58, 50: M12x1, Pin, 8-pole, A-coded or radial cable, 8-wire

TRA Ø 42: Radial cable, 8-wire

CONTACT ARRANGEMENT M12X1

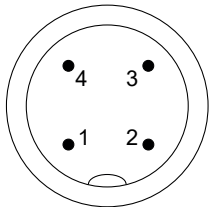

Pins, 4-pole, A-coded

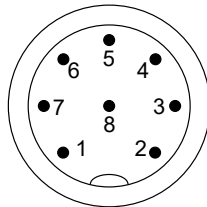

Pins, 8-pole, A-coded

The connection diagram is an integral part of the delivery and is enclosed with every device.

CONNECTION TABLE FOR SIGNAL OUTPUTS A, B, C

M12x1, 8-pole	M12x1, 4-pole	Connected with
1	1	+V _S = 18 to 28 VDC
2	2	-V _S = 0 VDC
3	3	Output: I _O = 0 (4) to 20 mA or V _O = 0 to 10 V
4	4	0V analogue common
5		MFP0
6		MFP1
7/8		Not connected

CONNECTION TABLE FOR SIGNAL OUTPUT D

M12x1, 8-pole	M12x1, 4-pole	Connected with
1	1	+V _S = +13 to +16 VDC
2	2	-V _S = -13 to -16 VDC
3	3	Output: V _O = -10 to +10 VDC
4	4	0V analogue common / V _S -GND (0 V)
5		MFP0
6		MFP1
7/8		Not connected

ORDER CODE FORMAT

TRA	58 -	K	A	3600	W	S	B	01	STANDARD VERSION
------------	-------------	----------	----------	-------------	----------	----------	----------	-----------	-------------------------

TRA	TBA - singleturn encoder with analogue output TRA - multiturn encoder with analogue output		
58	Design form (Ø)	42 50 58	Design form Ø 42 mm Design form Ø 50 mm Design form Ø 58 mm
K	Flange and shaft ¹	K KF KP KZ S ST SR SP	Clamped flange, shaft with flattened area Clamped flange, shaft with woodruff key Clamped flange, shaft with feather key Clamped flange, shaft for measuring gear ZRS (see datasheet ZRS11887) Synchro flange Synchro flange, shaft with flattened area Synchro flange, clamping shaft (stator coupling ZMS58 available according to ZMS12939) Synchro flange, shaft with feather key
A	Housing material	A S V	Aluminium 3.2315 Stainless steel 1.4305 Stainless steel 1.4404
3600	Measuring range	360 3600	360° (TBA standard) 3600° (TRA standard)
W	Code sense	W C	CW CCW
S	Electrical connection	S K Kx	Device connector M12 (not for design form 42) Cable, length 1m Cable, length x m (on request)
B	Output	A B C D	0 - 20 mA 4 - 20 mA 0 - 10 VDC ± 10 VDC
01	Electrical and mechanical variants*	01	Standard according to this data sheet

1) Standard combinations of design form, flange type and shaft diameter (mm). Other combinations on request.

Design form	Flange type							
	K	KF	KP	KZ	S	ST	SR	SZ
42					6	6		
50					12**	12**	12	
58	10	10	10	for ZRS	6	6	12	10

* The basic versions according to the data sheet bear the number 01. Deviations are identified with a variant number and are documented at TWK.

** For design form 50 the flange type with the flattened area is designated as S.

ACCESSORIES (SELECTION) - TO BE ORDERED SEPARATELY

MATING CONNECTORS

Order number, Datasheet	Type	Design & wire fixing	Housing-material	Cable ø & wire size	Shielding & IP grade
STK8GS54 , STK14567	M12-A 8-pole, female	Straight, screws	Die cast zinc nickel-plated	6 – 8 mm ≤ 0.5 mm ²	On housing IP67
STK8WS86 , -	M12-A 8-pole, female	Angled, screws	Die cast zinc nickel-plated	6 – 8 mm ≤ 0.5 mm ²	On housing IP67
STK8GS105 , -	M12-A 8-pole, female	Straight, screws	Stainless steel	5.5 – 8.6 mm ≤ 0.5 mm ²	On housing IP67
STK4GS60 , STK14572	M12-A 4-pole, female	Straight, screws	Die cast zinc nickel plated	4 – 6 mm ≤ 0.5 mm ²	On housing IP67

Please note: The position of the coding groove of the angled connector must be defined by the customer.

ANALOGUE HAND PROGRAMMING DEVICE

To program the encoder TRA/TBA with teach-in functionality.

PMA-05 See data sheet [PMA11443](#)

PLAY-FREE BELLOWS COUPLING

x and y: Bore diameter for shaft support

BKK 32 / x - y See data sheet [BKK11840](#)

PLAY-FREE CLAMP COUPLING

x and y: Bore diameter for shaft support

KK14S / x - y Without groove, see data sheet [KK12301](#)

KK14N / x - y With groove, see data sheet [KK12301](#)

MOUNTING BRACKETS

Mounting brackets for shaft encoder assembly.

KL66-2-S See data sheet [MZ10111](#)

TORQUE SUPPORT

Torque support/stator coupling. Suitable for use as a shaft encoder bracket for the clamping shaft version, for the offsetting of radial and axial drive shaft play for Ø 58 mm shaft encoders.

ZMS58 See data sheet [ZMS12939](#)

PLAY FREE MEASURING WHEEL

Play-free measuring wheel ZRS for slewing ring applications.

ZRS See data sheet [ZRS11877](#)

DOCUMENTATION

DOCUMENTATION

The following documents can be found in the Internet under www.twk.de/en in the documentation area, model TBA or TRA.

Data sheet [TBA/TRA14269](#)

Installation instructions [AN16169](#)

Reach compliant [QS15286](#)

RoHS compliant [QS13284](#)

CE Declaration of conformity [ZE12467](#)

UKCA Declaration of conformity [ZE16569](#)

INSTALLATION DRAWINGS

MODEL TBA58 - SX XXX X S X01

Dimensions in mm

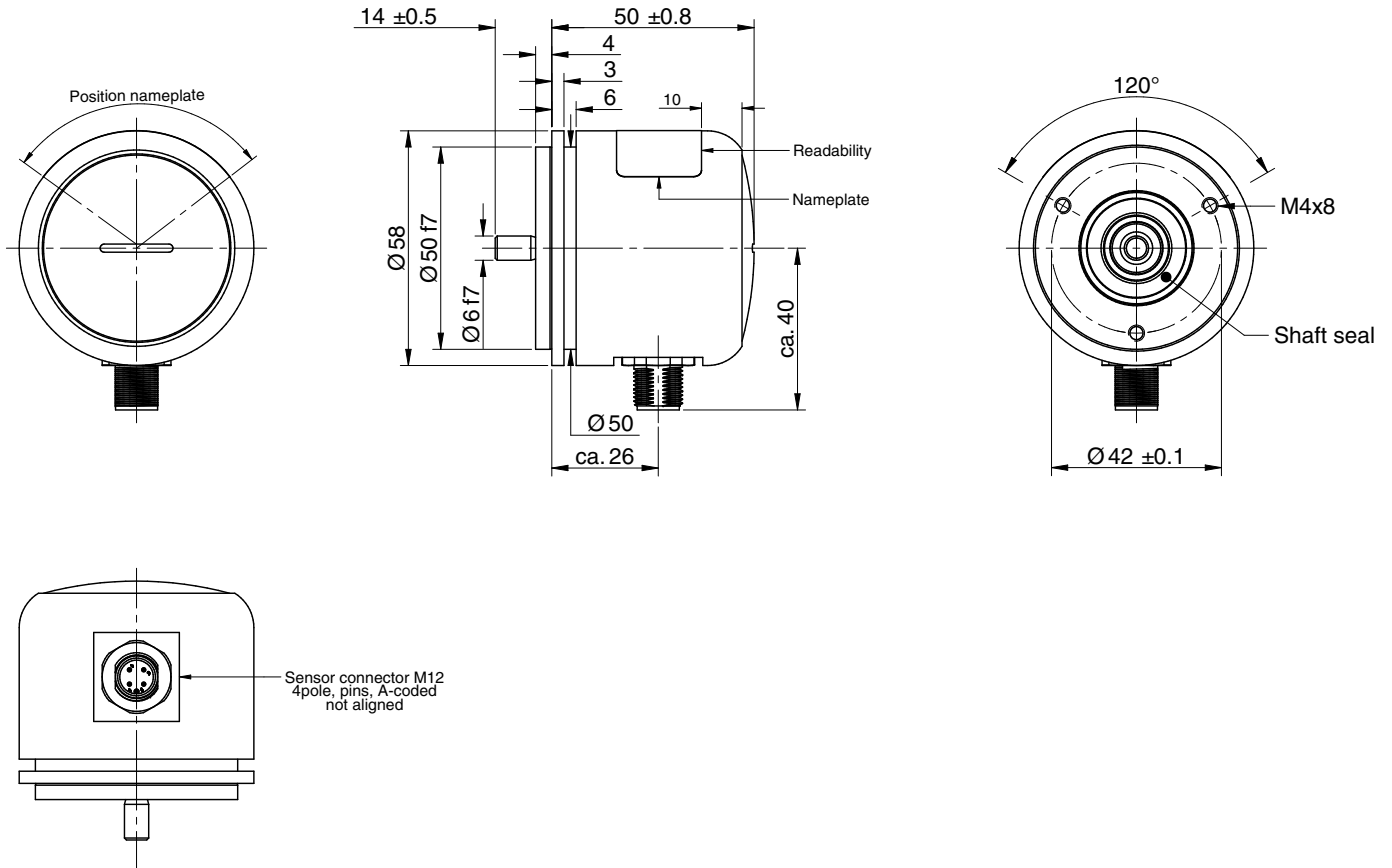

INSTALLATION DRAWINGS

MODEL TRA58 - KX XXXX X S X01

Dimensions in mm

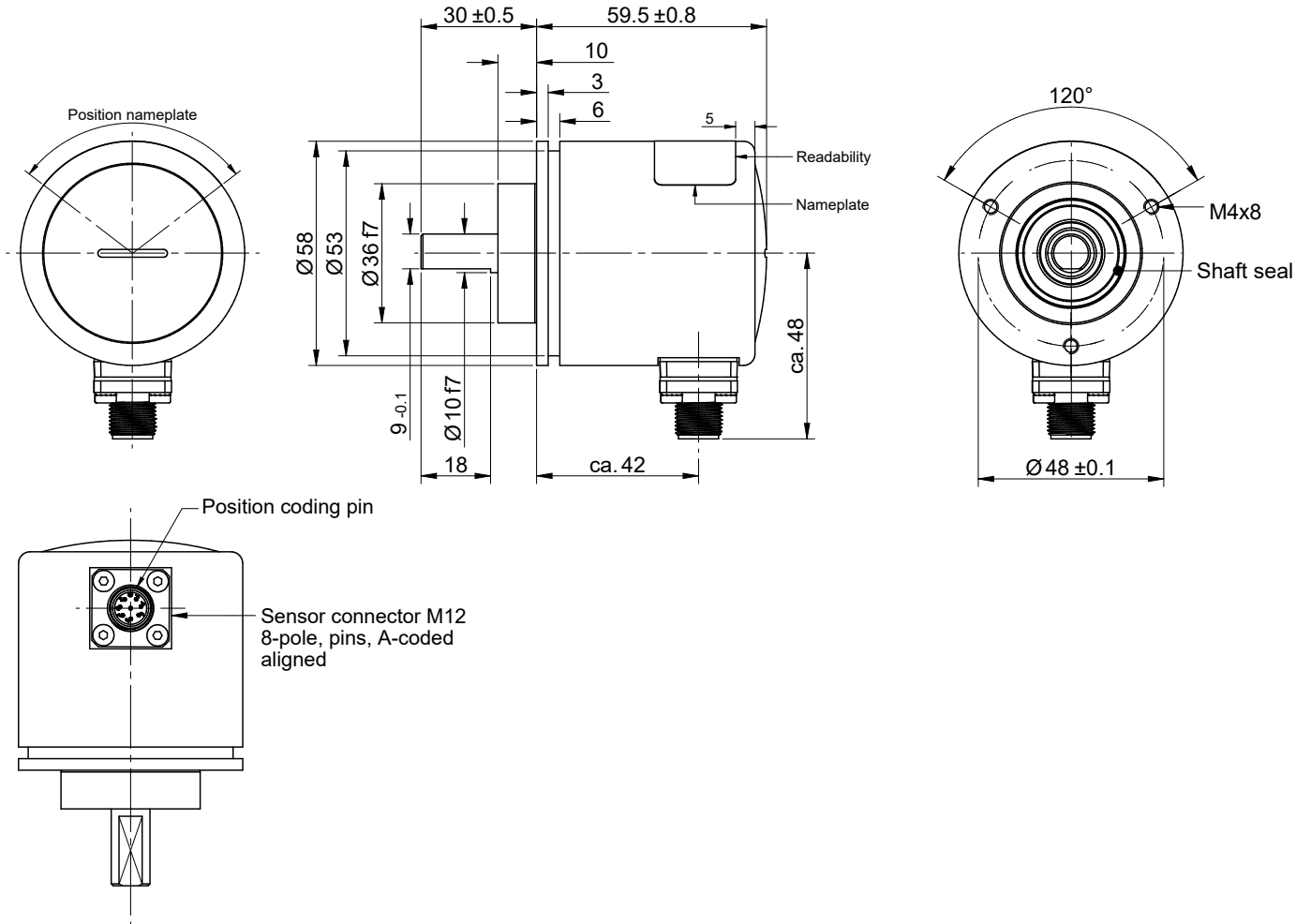

INSTALLATION DRAWINGS

MODEL TRA58 - SRX XXXX X S X01

Use torque support [ZMS12939](#) to avoid over-constraint mechanical fixture.

Dimensions in mm

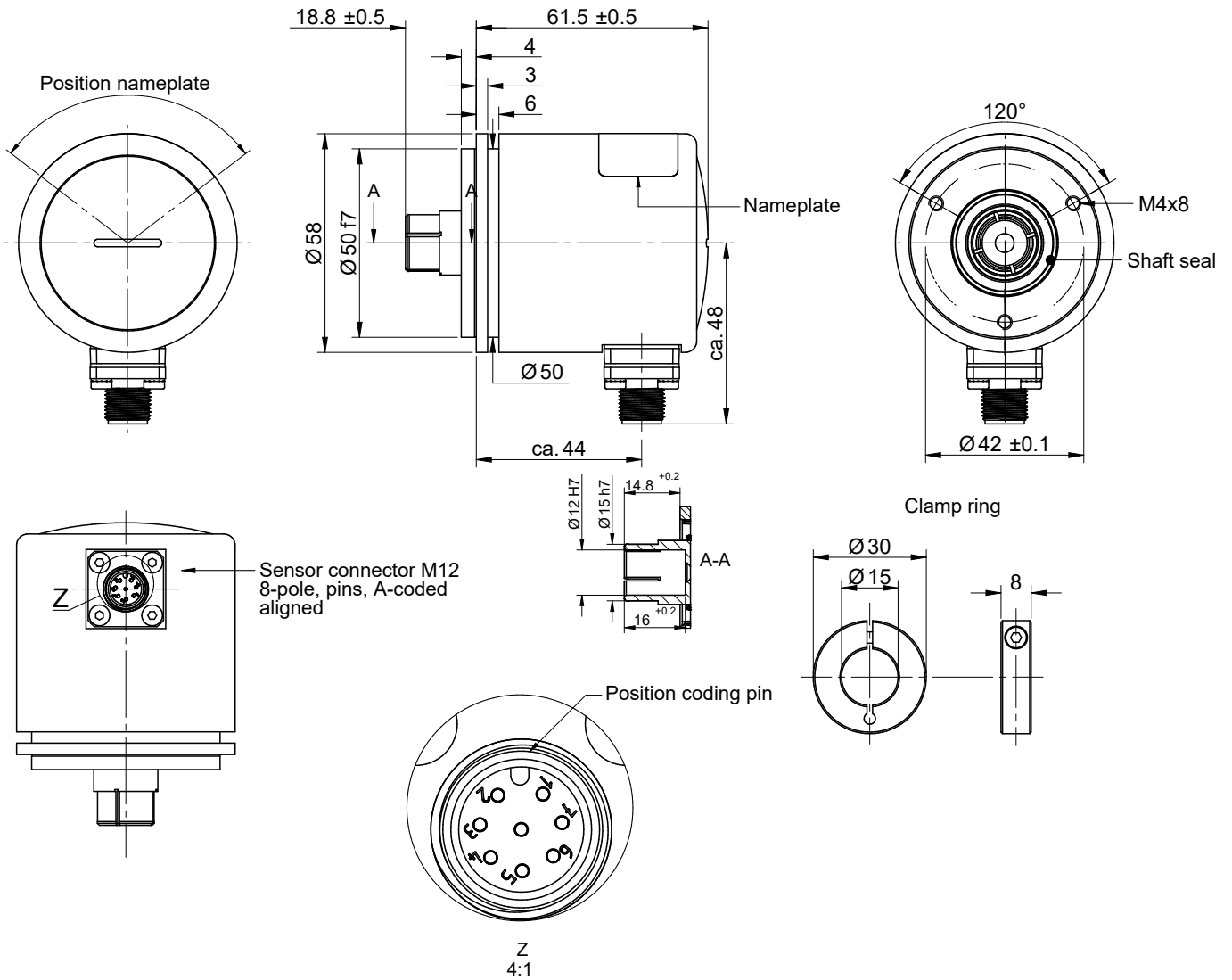

INSTALLATION DRAWINGS

MODEL TBA58 - KX XXX X S X100 (WITH M12-A, 8-POLE CONNECTOR AND TEACH-IN FUNCTION)

Dimensions in mm

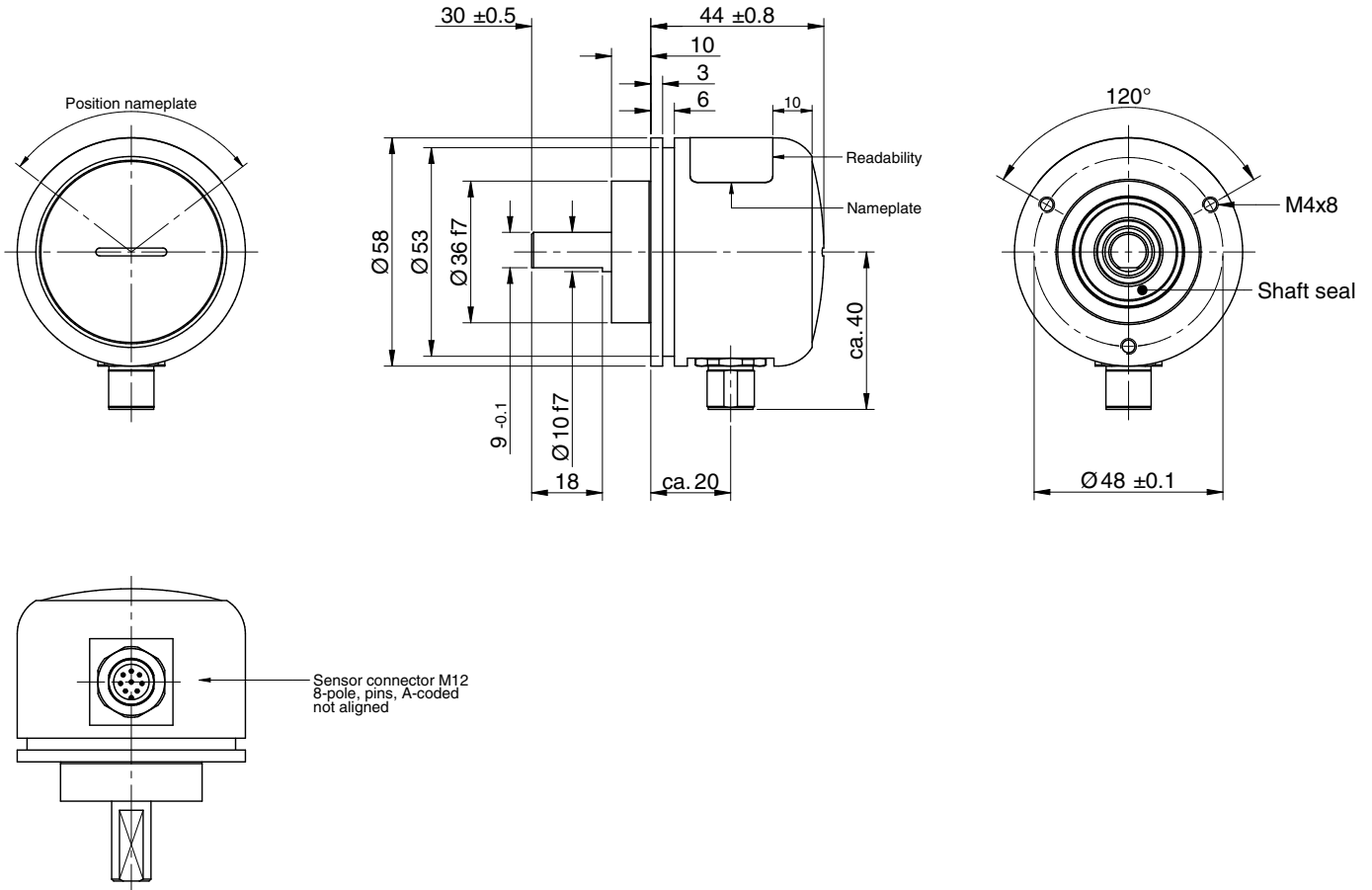

INSTALLATION DRAWINGS

MODEL TBA50 - SX XXX X S X01

Dimensions in mm

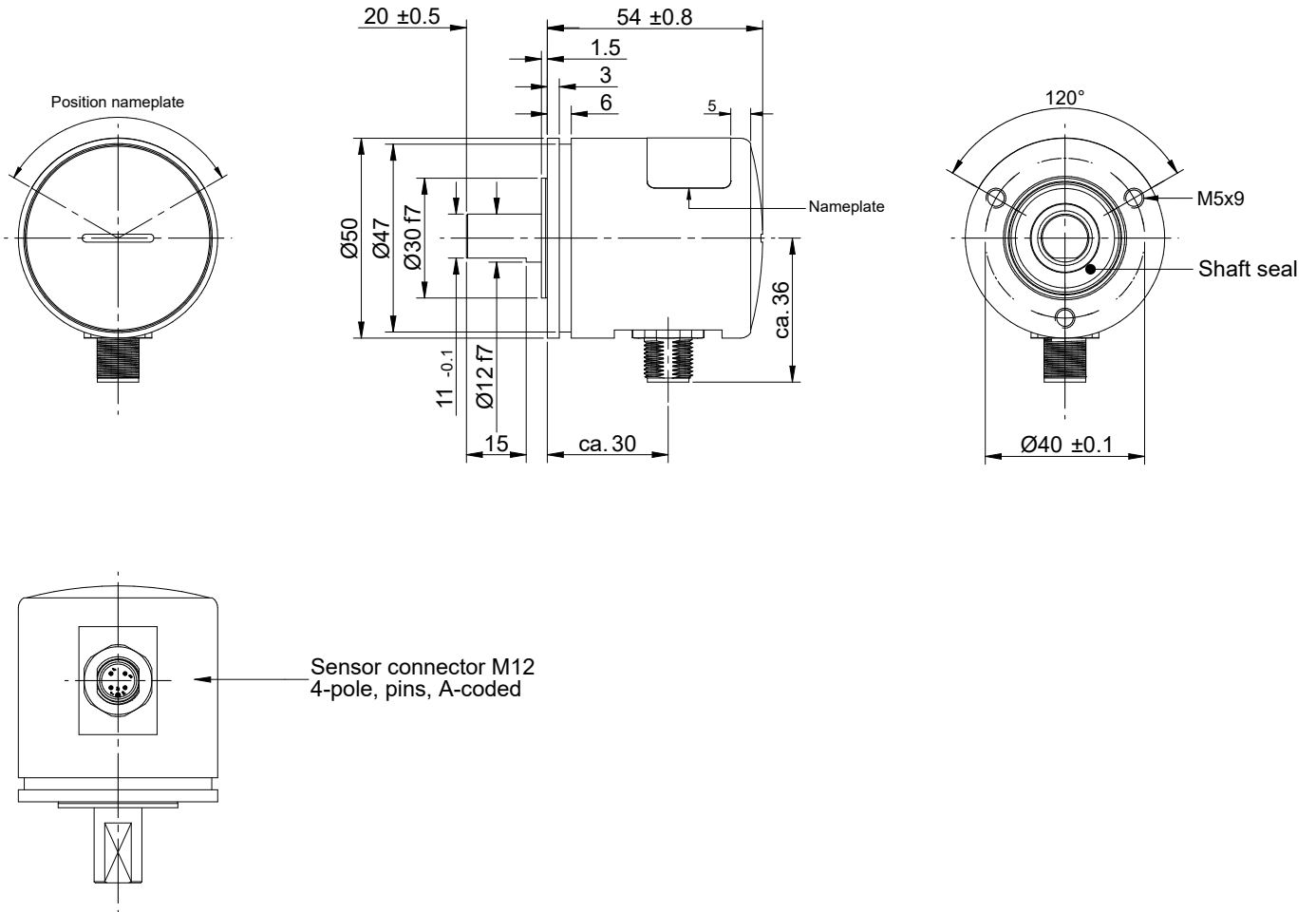

INSTALLATION DRAWINGS

MODEL TRA42 - SX XXXX X K X01

Dimensions in mm

